

**GOVERNMENT OF KHYBER PAKHTUNKHWA
IRRIGATION DEPARTMENT**



BID SOLICITATION DOCUMENTS

FOR

NAME OF WORK: - 210455-CONSTRUCTION OF FLOOD PROTECTION WORKS, IRRIGATION CHANNELS AND PONDS AND INSTALLATION OF SOLAR IRRIGATION TUBE WELLS IN KHYBER PAKHTUNKHWA, ADP NO.2267, DURING 2021-22.

SUB WORK: - CONSTRUCTION/UP-GRADATION OF TATONO BRIDGE (DOT-17) ON MAIN LOWER SWAT CANAL DISTRICT CHARASADDA

E/COST RS IN: 100.4941 MILLION

NAME OF CONTRACTOR: _____

CHARASADDA IRRIGATION DIVISION CHARASADDA

MAY 2022

NOTICE FOR INVITING E-BIDDING (2ND TIME)
SINGLE STATE SINGLE ENVELOPE PROCEDURE

Charsadda Irrigation Division Charsadda, Irrigation Department Government of Khyber Pakhtunkhwa invites Electronic Bids from eligible firms/bidders in accordance with KPPRA Procurement Rules 2014 on Single Stage single Envelope Procedure for the following work:-

S#	Name of work/Sub-work	E/Cost Rs. In (M)	Earnest Money +Stamp Duty + Professional Tax	PEC Category and relevant Code
1	210455-Construction of Flood Protection works, Irrigation Channels and Ponds and Installation of Solar Irrigation Tube Wells in Khyber Pakhtunkhwa, ADP No.2267, during 2021-22. <u>Sub-work:-</u> Construction/Up-Gradation of Tatono Bridge (Dot-17) on Main Lower Swat Canal District Charsadda.	100.4941	2149842/-	Category C-4 and above Spec:Code CE-02 & CE-04

Terms & Conditions:-

1. Bid Solicitation documents containing all the terms and conditions and other relevant instructions for the work can be downloaded from the Department and or KPPRA websites (www.irrigation.gkp.pk)/(www.kppra.gov.pk).
2. Electronic Bidding shall be done on “above/below system” on BOQ/Engineer’s estimate.
3. All bidder are required to have registration with Khyber Pakhtunkhwa Revenue Authority.
4. The bidder shall submit 02% bid security, of the estimated cost as mentioned above, in the shape of deposit at call (Original) along with their bid before closing date and time.
5. Notification issued by KPPRA pertaining to procurement process issued from time to time shall be applicable.
6. If the evaluated electronic bid costs of two or more bidders are equal, then the successful bidder will be declared through draw/toss.
7. Pre-bid meeting will be held on 01-06-2022 at 11.00 AM in the office of Executive Engineer, Charsadda Irrigation Division, Charsadda.
8. The last date & time for submission of the Bid along with relevant documents is 07-06-2022 upto 11.30 AM which will be opened on the same day at 12.00 Noon in the office of the undersigned in presence of Contractor and their representatives who wishes to attend.
9. Bid security of the 1st, 2nd and 3rd lowest Electronic Bidder will be retained by the employer till the approval of bids by the competent Authority.
10. All Govt: Notifications/Rules/Taxes updated from time to time shall be applicable.

Executive Engineer
Charsadda Irrigation Division
Charsadda Phone & Fax # 091-6514641

STANDARD FORM OF BIDDING DOCUMENTS

FOR

PROCUREMENT OF WORKS

(CIVIL WORKS)

(For Large Contracts)

Over Rs.45 Million

Notified vide Notification No. KPPRA/M&E/SBDs/1-1/2015

Dated Peshawar the May 03, 2016

**KHYBER PAKHTUNKHWA PUBLIC PROCUREMENT
REGULATORY AUTHORITY (KPPRA)**

TABLE OF CONTENTS

Description

No. INVITATION FOR BIDS

Form

INSTRUCTIONS TO BIDDERS

A. General

- IB.1 Scope of Bid
- IB.2 Source of Funds
- IB.3 Eligible Bidders
- IB.4 One Bid Per Bidder
- IB.5 Cost of Bidding
- IB.6 Site Visit

B. Bidding Documents

- IB.7 Contents of Bidding Documents
- IB.8 Clarification of Bidding Documents
- IB.9 Amendment of Bidding Documents

C. Preparation of Bids

- IB.10. Language of Bid
- IB.11 Documents Accompanying the Bid
- IB.12 Bid Prices
- IB.13 Currencies of Bid and Payment
- IB.14 Bid Validity
- IB.15 Bid Security
- IB.16 Alternate Proposals by Bidder
- IB.17 Pre-Bid Meeting
- IB.18 Format and Signing of Bid

D. Submission of Bids

- IB.19 Sealing and Marking of Bids
- IB.20 Deadline for Submission of Bids
- IB.21 Late Bids
- IB.22 Modification, Substitution and Withdrawal of Bids

E. Bid Opening and Evaluation

- IB.23 Bid Opening
- IB.24 Process to be Confidential
- IB.25 Clarification of Bids
- IB.26 Examination of Bids and Determination of Responsiveness
- IB.27 Correction of Errors
- IB.28 Evaluation and Comparison of Bids

F. Award of Contract

- IB.29 Award
- IB.30 Procuring Entity's Right to Accept any Bid and to Reject any or all Bids
- IB.31 Notification of Award
- IB.32 Performance Security
- IB.33 Signing of Contract Agreement
- IB.34 General Performance of the Bidders
- IB.35 Integrity Pact
- IB.36 Instructions Not Part of Contract

BIDDING DATA

FORM OF BID AND APPENDICES TO BID

FORM OF BID

- Appendix-A to Bid : Special Stipulations
- Appendix-B to Bid : Foreign Currency Requirements
- Appendix-C to Bid : Price Adjustment (Under Clause 70)
- Appendix-D to Bid : Bill of Quantities
- Appendix-E to Bid : Proposed Construction Schedule
- Appendix-F to Bid : Method of Performing the Work
- Appendix-G to Bid : List of Major Equipment – Related Items
- Appendix-H to Bid : Construction Camp and Housing Facilities
- Appendix-I to Bid : List of Subcontractors
- Appendix-J to Bid : Estimated Progress Payments
- Appendix-K to Bid : Organization Chart of the Supervisory Staff and Labour
- Appendix-L to Bid : Integrity Pact

FORMS

- BID SECURITY
- PERFORMANCE SECURITY
- CONTRACT AGREEMENT
- MOBILIZATION ADVANCE GUARANTEE/BOND

PART-I: GENERAL CONDITIONS OF CONTRACT

PART-II: PARTICULAR CONDITIONS OF CONTRACT

SPECIFICATIONS - SPECIAL PROVISIONS

SPECIFICATIONS - TECHNICAL PROVISIONS

DRAWINGS

**INVITATION
FOR BIDS**

KPPRA NOTOFICATION
(Updated from Time to Time)



GOVERNMENT OF KHYBER PAKHTUNKHWA,
KHYBER PAKHTUNKHWA
PUBLIC PROCUREMENT REGULATORY AUTHORITY

Peshawar, the May 10, 2022 / 6058-71

NOTIFICATION

S.R.O. (14)/Vol: 1-24/2021-22: In exercise of the powers conferred under Section 35-A of the Khyber Pakhtunkhwa Public Procurement Regulatory Authority Act, 2012 (Khyber Pakhtunkhwa Act No. XI of 2012) the Authority has been pleased to issue the following regulation, namely: -

1. **Short title and commencement.-** (i) This regulation may be called the Khyber Pakhtunkhwa Public Procurement Regulation No. XIV 2022.
(ii) This shall come into force at once.
2. **Matters pertaining to Additional Security in case of abnormally low bids.-** This regulation relates to the matters pertaining to Additional Security submitted by the bidders in procurement of works.
 - i. The contractors quoting their bids up to a limit of 10% below Engineer estimate shall submit bid security @ 2% only of Engineer Estimate.
 - ii. The contractors quoting their bids more than 10% below upto 20% below on Engineers' Estimate shall submit along with their bids 8% Additional Security of Engineer's Estimated cost in addition to 2% bid security. If the bid is not accompanied with the required amount of additional security then it will be considered as non-responsive and the 2% bid security shall be forfeited in favour of Government and the second lowest bidder and so on will be considered accordingly.
 - iii. [Similarly, a contractor quoting bid more than 20% below shall submit with his bid an additional security on Engineer's Estimated cost equal to the differential amount of submitted bid and Engineers' Estimate along with detailed rate analysis]¹. In case of more than 20% below bids, if the bid is not accompanied by the detailed rate analysis and / or required amount of additional security, then the said bid shall be considered as non-responsive. All the securities submitted along with such non-responsive bid shall be forfeited in favour of Government and the 2nd lowest bidder and so on will be considered accordingly.
 - iv. In case detailed rate analysis submitted with the bids is, in view of the Procuring Entity, not convincing, the Head of the Procuring Entity may declare such bid as non-responsive without any forfeiture of bid securities and record reasons thereof.
 - v. The procuring entity may offer the contract to next lowest bidder after due diligence in the context of financial difference between such two bids or may advertise procurement opportunity afresh.

¹ Differential amount; If a contractor quote, e.g. 25% below engineer estimate bid then he has to deposit along with his bid 2% bid security and 25% additional security of engineer estimate.

- vi. After commencements of work by the successful bidder, the procuring entity may replace the Additional Security with a bank guarantee of the same amount from the scheduled bank; if the already deposited security is not in the form of bank guarantee.
- vii. The Additional Security shall be released to the contractor in four installments i.e. 1st installment of 25% to be released upon completion of 25% of the project, 2nd installment of 25% to be released upon completion of 50% of the project, 3rd installment of 25% to be released upon completion of 75% of the project and the 4th installment of 25% to be released after 100% completion of the project.
- viii. All previous orders, instructions and regulations issued regarding additional security shall stand superseded.

-SD-
Managing Director
KPPRA

ENDST: No. As above:

Peshawar, the May 10, 2022

Copy forwarded to:-

1. The Additional Chief Secretary (P&D) Department, Govt. of Khyber Pakhtunkhwa.
2. The Administrative Secretaries (C&W, Irrigation, Public Health Engineering and Local Government, Elections & Rural Development Department) Khyber Pakhtunkhwa with request to circulate the same to their downstream formations for compliance.
3. The Principal Secretary to Governor, Khyber Pakhtunkhwa.
4. The Principal Secretary to Chief Minister, Khyber Pakhtunkhwa.
5. The Inspector General of Police, Khyber Pakhtunkhwa.
6. The Secretary Provincial Assembly, Khyber Pakhtunkhwa.
7. The Accountant General, Khyber Pakhtunkhwa.
8. The Registrar, Peshawar High Court, Peshawar.
9. All Commissioners and Deputy Commissioners in Khyber Pakhtunkhwa.
10. PSO to Chief Secretary, Govt. of Khyber Pakhtunkhwa.
11. All Heads of Autonomous/Semi-Autonomous Bodies in Khyber Pakhtunkhwa.
12. Director, Treasuries & Accounts with request to circulate the same to all DAOs & Treasuries Officers in Khyber Pakhtunkhwa.
13. The Section Officer (Admn), Finance Department, Govt. of Khyber Pakhtunkhwa with respect to his office letter No. SO(A)/FD/1-40/2022, dated 22.04.2022.
14. Manager, Stationery and Printing Press Khyber Pakhtunkhwa, for printing in the official gazette.

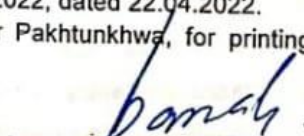
SANA ULLAH
Assistant Director (M&E), KPPRA

INSTRUCTIONS TO BIDDERS

INSTRUCTIONS TO BIDDERS

A. GENERAL

IB.1 Scope of Bid

- 1.1 The Procuring Entity as defined in the Bidding Data hereinafter called “**Executive Engineer, Charsadda Irrigation Division Charsadda on Behalf of Chief Engineer (South) Irrigation Department**” invites bids for the construction and completion of each sub work tabulated in the title page and summarized in the Bidding Data hereinafter referred to as the “Works”.
- 1.2 The successful bidder will be expected to complete the Works within the time specified in Appendix-A to Bid.
- 1.3 Throughout these bidding documents, the terms ‘bid’ and ‘tender’ and their derivatives (bidder / tenderer, bid / tender, bidding / tendering etc.) are synonymous and refer to each sub work as per title page separately.

IB.2 Source of Funds

- 2.1 The Procuring Entity intends to execute the works from Provincial ADP as tabulated in the title page.

IB.3 Eligible Bidders

- 3.1 This Invitation for Bids is open to all bidders meeting the following requirements which are considered to be mandatory and making them eligible: the below details to be provide.
 - a. Duly licensed by the Pakistan Engineering Council (PEC) in the category mentioned in the NIT.
 - b. Registered with KPRA
 - c. NTN/Registration certificate.
 - d. The specialty code of Pakistan Engineering Council (PEC) is must. (as per NIT)
 - e. The bidder shall provide work the completion certificate for the work either completed or ongoing equivalent to 50% of the estimated cost of the work he is applying for. Upto two certificates would be such. For flood works completed certificates of flood works would be considered. For Bridge work the completion / ongoing work certificate as monition above will be required.
 - f. Enlistment with the Government works Department in relevant categories.

- 3.2 A bidder having a conflict of interest will be declared as non-responsive if the bidder has a close business relationship with the Procuring Entity's professional personnel, who directly or indirectly involved in any part of: (i) the preparation of the bidding documents for the Works, (ii) the Bid evaluation or (iii) the supervision of such Works.

IB.4 One Bid per Bidder

- 4.1 Not Applicable

IB.5 Cost of Bidding

- 5.1 The bidder shall bear all costs including bid solicitation documents fee (nominal so as to cover printing/reproduction and mailing costs) and other costs associated with the preparation and submission of its bid including the submitted Bid Securities and Additional Security (If applicable) and the Procuring Entity will in no case be responsible or liable for those costs, regardless of the conduct or outcome of the bidding process.

IB.6 Site Visit

- 6.1 The bidders are advised to visit and examine the site of Works and its surroundings and obtain for themselves on their own responsibility all information that may be necessary for preparing the bid and entering into a contract for construction of the Works. All cost in this respect shall be at the bidder's own expense.
- 6.2 The bidders and any of their personnel or agents will be granted permission by the Procuring Entity to enter upon his premises and lands for the purpose of such inspection, but only upon the express condition that the bidders, their personnel and agents, will release and indemnify the Procuring Entity, his personnel and agents from and against all liability in respect thereof and will be responsible for death or personal injury, loss of or damage to property and any other loss, damage, costs and expenses incurred as a result of such inspection.

B. BIDDING DOCUMENTS

IB.7 Contents of Bidding Documents

- 7.1 The Bidding Documents, in addition to invitation for bids, are those stated below and should be read in conjunction with any Addenda issued in accordance with Clause IB.9.
1. Instructions to Bidders.
 2. Bidding Data.
 3. General Conditions of Contract, Part-I (GCC).
 4. Particular Conditions of Contract, Part-II (PCC).
 5. Specifications – Special Provisions.
 6. Specifications - Technical Provisions.
 7. Form of Bid & Appendices to Bid.
 8. Bill of Quantities (Appendix-D to Bid).
 9. Form of Bid Security.
 10. Form of Contract Agreement.
 11. Forms of Performance Security and Mobilization Advance Guarantee/Bond.
 12. Drawings.

- 7.2 The bidders are expected to examine carefully the contents of all the above documents. Failure to comply with the requirements of bid submission will be at the Bidders own risk. Pursuant to Clause IB.26, bids which are not substantially responsive to the requirements of the Bidding Documents will be rejected.

IB.8 Clarification of Bidding Documents

- 8.1 Any prospective bidder requiring any clarification (s) in respect of the Bidding Documents may notify the Procuring Entity in writing at the Procuring Entity's address indicated in the Invitation for Bids. The Procuring Entity will respond to any request for clarification which he receives earlier than 7 days prior to the deadline for submission of bids.

Copies of the Procuring Entities response will be forwarded to all purchasers of the Bidding Documents, including a description of the enquiry but without identifying it's source.

IB.9 Amendment of Bidding Documents

- 9.1 At any time prior to the deadline for submission of bids, the Procuring Entity may, for any reason, whether at his own initiative or in response to a clarification requested by a prospective bidder, modify the Bidding Documents by issuing addendum.
- 9.2 Any addendum thus issued shall be part of the Bidding Documents pursuant to Sub-Clause 7.1 hereof and shall be communicated in writing to all purchasers of the Bidding Documents. Prospective bidders shall acknowledge receipt of each addendum in writing to the Procuring Entity.
- 9.3 To afford prospective bidders reasonable time in which to take an addendum into account in preparing their bids, the Procuring Entity may extend the deadline for submission of bids in accordance with Clause IB.20 (10)

C. PREPARATION OF BIDS

IB.10 Language of Bid

- 10.1 The bid and all correspondence and documents related to the bid exchanged by a bidder and the Procuring Entity shall be in the bid language stipulated in the Bidding Data and Particular Conditions of Contract. Supporting documents and printed literature furnished by the bidders may be in any other language provided the same are accompanied by an accurate translation of the relevant parts in the bid language, in which case, for purposes of evaluation of the bid, the translation in bid language shall prevail.

IB.11 Documents Accompanying the Bid

- 11.1 Each bidder shall:
- (a) submit a written power of attorney authorizing the signatory of the bid to act for and on behalf of the bidder.

- (b) update the information indicated and listed in the Bidding Data and previously submitted with the application for prequalification, and continue to meet the minimum criteria set out in the prequalification documents which as a minimum, would include the following (If applicable):
 - (i) Evidence of access to financial resources along with average annual construction turnover;
 - (ii) Financial predictions for the current year and the two following years including the effect of known commitments;
 - (iii) Work commitments since prequalification;
 - (iv) Current litigation information; and
 - (v) Availability of critical equipment.

and

- (c) furnish a technical proposal taking into account the various Appendices to Bid specially the following (If applicable):

Appendix-E to Bid Proposed Construction Schedule Appendix-F to Bid Method of Performing the Work Appendix-G to Bid List of Major Equipment Appendix-K to Bid Organization Chart for Supervisory Staff and other pertinent information such as mobilization program etc;

11.2 Bids submitted by a joint venture of two (2) or more firms shall comply with the following requirements:

- (a) the bid and in case of a successful bid, the Form of Contract Agreement shall be signed so as to be legally binding on all partners;
- (b) one of the joint venture partners shall be nominated as being in charge; and this authorization shall be evidenced by submitting a power of attorney signed by legally authorized signatories of all the joint venture partners;
- (c) the partner-in-charge shall always be duly authorized to deal with the Procuring Entity regarding all matters related with and/or incidental to the

execution of Works as per the terms and Conditions of Contract and in this regard to incur any and all liabilities, receive instructions, give binding undertakings and receive payments on behalf of the joint venture;

- (d) all partners of the joint venture shall at all times and under all circumstances be liable jointly and severally for the execution of the Contract in accordance with the Contract terms and a statement to this effect shall be included in the authorization mentioned under Sub-Para(b) above as well as in the Form of Bid and in the Form of Contract Agreement (in case of a successful bid); and
- (e) a copy of the agreement entered into by the joint venture partners shall be submitted with the bid stating the conditions under which it will function, its period of duration, the persons authorized to represent and obligate it and which persons will be directly responsible for due performance of the Contract and can give valid receipts on behalf of the joint venture, the proportionate participation of the several firms forming the joint venture, and any other information necessary to permit a full appraisal of its functioning. No amendments / modifications whatsoever in the joint venture agreement shall be agreed to between the joint venture partner without prior written consent of the Procuring Entity.

- 11.3 Bidders shall also submit proposals of work methods and schedule, in sufficient detail to demonstrate the adequacy of the Bidders' proposals to meet the technical specifications and the completion time referred to in Sub-Clause 1.2 hereof (If deemed necessary).

IB.12 Bid Prices

- 12.1 Unless stated otherwise in the Bidding Documents, the Contract shall be for the whole of the Works as described in Sub-Clause 1.1 hereof, based on the unit rates and / or prices submitted by the bidder.
- 12.2 The bidders shall fill in rates premiums and prices for all items of the Works described in the Bill of Quantities. Premium/unit rate offered for an item shall be considered upto two significant decimals places for evaluation purposes. Items against which no premium/rate or price is entered by a bidder will not be paid for by the Procuring Entity when executed and shall be deemed covered by premium/rates and prices for other items in the Bill of Quantities. Corrections in premium/rates and prices, if any, shall be made by crossing out, initialing, dating and re-writing.
- 12.3 All duties, taxes and other levies payable by the Contractor under the Contract, or for any other cause, shall be considered by the bidder in quoting his bid on E-bidding System.

Additional / reduced duties, taxes and levies due to subsequent additions or changes in legislation shall be reimbursed / deducted as per Sub-Clause 70.2 of the General Conditions of Contract Part-I.

- 12.4 The premium/rates and prices quoted by the bidders are not subject to adjustment during the performance of the Contract in accordance with the provisions of Clause 70 of the Conditions of Contract.

IB.13 Currencies of Bid and Payment

- 13.1 The unit rates/premium and the prices shall be quoted by the bidder entirely in Pak rupees. A bidder expecting to incur expenditures in other currencies for inputs to the Works supplied from outside the Procuring Entity's country (referred to as the "Foreign Currency Requirements") shall indicate the same in Appendix-B to Bid. The proportion of the Bid Price (excluding Provisional Sums) needed by him for the payment of such Foreign Currency Requirements either (i) entirely in the currency of the Bidder's home country or, (ii) at the bidder's option, entirely in Pak rupees provided always that a bidder expecting to incur expenditures in a currency or currencies other than those stated in (i) and (ii) above for a portion of the foreign currency requirements, and wishing to be paid accordingly, shall indicate the respective portions in his bid.
- 13.2 The rates of exchange to be used by the bidder for currency conversion shall be the TT&OD Selling Rates published or authorized by the State Bank of Pakistan prevailing on the date 28 days prior to the deadline for submission of bids.

For the purpose of payments, the exchange rates used in bid preparation shall apply for the duration of the Contract.

IB.14 Bid Validity

- 14.1 Bids shall remain valid for the period stipulated in the Bidding Data after the Date of Bid Opening specified in Clause IB.23.
- 14.2 In exceptional circumstances, prior to expiry of the original bid validity period, the Procuring Entity may request that the bidders extend the period of validity for a specified additional period which shall in no case be more than the original bid validity period. The request and the responses thereto shall be made in writing. A bidder may refuse the request without forfeiting his Bid Security. A bidder agreeing to the request will not be required or permitted to modify his bid, but will be required to extend the validity of his Bid Security for the period of the extension, and in compliance with Clause IB.15 in all respects. The bidder shall bear all costs to be incurred on such extensions.

IB.15 Bid Security

- 15.1 Each bidder shall furnish, as part of his bid, at the option of the bidder, a Bid Security in the amount stipulated in NIT in Pak. Rupees in the form of Deposit at Call [Deleted]1 in favour of the Procuring Entity. [The bid security shall be submitted from the account of the firm/bidder/contractor who submits the bid]
- 15.2 The Bid Security shall be in the form of Deposit at Call from a Scheduled Bank in Pakistan, in favour of the Procuring Entity.
- 15.3 Any bid not accompanied by an acceptable Bid Security & Additional Security (If Applicable) shall be rejected by the Procuring Entity as non-responsive.
- 15.4 The bid securities of unsuccessful bidders will be returned as promptly as possible and those of first three may be retained till award of contract.
- 15.5 [“The bid security of the successful bidder shall be retained with the Procuring Entity till completion of the defect liability period and the amount of guarantee will be reduced by an equivalent amount”.]
- 15.6 The Bid Security may be forfeited:
 - (a) if the bidder withdraws his bid except as provided in Sub-Clause 22.1;
 - (b) if the bidder does not accept the correction of his Bid Price pursuant to Sub-Clause 27.2 hereof; or

- (c) In the case of successful bidder, if he fails within the specified time limit to:
 - (i) furnish the required Performance Security; or
 - (ii) sign the Contract Agreement.
- (d) If the bidder fails to Submit additional security as per KPPRA Notification No. S.R.O. (14)/Vol: 1-24/2021-22:, Dated Peshawar, the 10th May 2022 /6058-71.

IB.16 Alternate Proposals by Bidder (Not Applicable)

- 16.1 Should any bidder consider that he can offer any advantages to the Procuring Entity by a modification to the designs, specifications or other conditions, he may, in addition to his bid to be submitted in strict compliance with the Bidding Documents, submit any Alternate Proposal(s) containing (a) relevant design calculations; (b) technical specifications; (c) proposed construction methodology; and (d) any other relevant details / conditions, provided always that the total sum entered on the Form of Bid shall be that which represents complete compliance with the Bidding Documents.
- 16.2 Alternate Proposal(s), if any, of the lowest evaluated responsive bidder only may be considered by the Procuring Entity as the basis for the award of Contract to such bidder.

IB.17 Pre-Bid Meeting

- 17.1 The Procuring Entity may, on his own motion or at the request of any prospective bidder(s), hold a pre-bid meeting to clarify issues and to answer any questions on matters related to the Bidding Documents or any other matter that may be raised at that stage. The date, time and venue of pre- bid meeting, if convened, is as stipulated in the NIT. All prospective bidders or their authorized representatives can attend such a pre- bid meeting.
- 17.2 The bidders are requested to submit questions, if any, in writing so as to reach the Procuring Entity not later than seven (7) days before the proposed pre-bid meeting.
- 17.3 Minutes of the pre-bid meeting, including the text of the questions raised and the replies given, will be transmitted without delay to all purchasers of the Bidding Documents. Any modification of the Bidding Documents listed in Sub-Clause 7.1 hereof which may become necessary as a result of the pre-bid meeting shall be made by the Procuring Entity exclusively through the issue of an Addendum pursuant to Clause IB.9 and not through the minutes of the pre-bid meeting.
- 17.4 Absence at the pre-bid meeting will not be a cause for disqualification of a bidder.

IB.18 Format and Signing of Bid

- 18.1 Bidders are particularly directed that the amount entered on the Form of Bid shall be for performing the Contract strictly in accordance with the Bidding Documents. (In the instant case E-Bidding system is utilized)
- 18.2 All appendices to Bid are to be properly completed and signed.
- 18.3 No alteration is to be made in the Form of Bid nor in the Appendices thereto except in filling up the blanks as directed. If any such alterations be made or if these instructions be not fully complied with, the bid may be rejected.
- 18.4 Each bidder shall prepare by filling out the forms completely and without alterations one (1) original and number of copies, specified in the Bidding Data, of the documents comprising the bid as described in Clause IB.7 and clearly mark them "ORIGINAL" and "COPY" as appropriate. In the event of discrepancy between them, the original shall prevail.
- 18.5 The original and all copies of the bid shall be typed or written in indelible ink (in the case of copies, photostats are also acceptable) and shall be signed by a person or persons duly authorized to sign on behalf of the bidder pursuant to Sub- Clause 11.1(a) hereof. All pages of the bid shall be initialed and stamped by the person or persons signing the bid.
- 18.6 The bid shall contain no alterations, omissions or additions, except to comply with instructions issued by the Procuring Entity, or as are necessary to correct errors made by the bidder, in which case such corrections shall be initialed by the person or persons signing the bid.
- 18.7 Bidders shall indicate in the space provided in the Form of Bid their full and proper addresses at which notices may be legally served on them and to which all correspondence in connection with their bids and the Contract is to be sent.
- 18.8 Bidders should retain a copy of the Bidding Documents as their file copy.

D. SUBMISSION OF BIDS

IB.19 Sealing and Marking of Bids

- 19.1 Each bidder shall submit his bid as under: (one original complete marked)
 - (a) ORIGINAL and each copy of the Bid shall be separately sealed and put in separate envelopes and marked as such containing the applicable deposit at calls, printed and signed copy of tender form from E-bidding System.
 - (b) The envelopes containing the ORIGINAL and copies will be put in one sealed envelope and addressed / identified as given in Sub- Clause 19.2 hereof.

- 19.2 The inner and outer envelopes shall:
- (a) be addressed to the Procuring Entity at the address provided in the Bidding data;
 - (b) bear the name and identification number of the contract as defined in the Bidding Data/Title page/NIT; and
 - (c) provide a warning not to open before the time and date for bid opening, as specified in the Bidding Data.
- 19.3 In addition to the identification required in Sub- Clause 19.2 hereof, the inner envelope shall indicate the name and address of the bidder to enable the bid to be returned unopened in case it is declared “late” pursuant to Clause IB.21
- 19.4 If the outer envelope is not sealed and marked as above, the Procuring Entity will assume no responsibility for the misplacement or premature opening of the Bid.

IB.20 Deadline for Submission of Bids

- 20.1 (a) Complete Bids must be received by the Procuring Entity at the address specified no later than the time and date stipulated in the Bidding Data/NIT
In the event of the specified date for the submission of bids declared a holiday for the Procuring Entity, the Bids will be received up to the appointed time on the next working day.
- (b) Bids with charges payable will not be accepted, nor will arrangements be undertaken to collect the bids from any delivery point other than that specified above. Bidders shall bear all expenses incurred in the preparation and delivery of bids. No claims will be entertained for refund of such expenses.
 - (c) Where delivery of a bid is by mail and the bidder wishes to receive an acknowledgment of receipt of such bid, he shall make a request for such acknowledgment in a separate letter attached to but not included in the sealed bid package.
 - (d) Upon request, acknowledgment of receipt of bids will be provided to those making delivery in person or by messenger.
- 20.2 The Procuring Entity may, at his discretion, extend the deadline for submission of bids by issuing an amendment in accordance with Clause IB.9, in which case all rights and obligations of the Procuring Entity and the bidders previously subject to the original deadline will thereafter be subject to the deadline as extended.

IB.21 Late Bids

- 21.1 (a) Any bid received by the Procuring Entity after the deadline for submission of bids prescribed in Clause IB.20 will be returned unopened to such bidder.

- (b) Delays in the mail, delays of person in transit, or delivery of a bid to the wrong office or due to any other reason, shall not be accepted as an excuse for failure to deliver a bid at the proper place and time. It shall be the bidder's responsibility to determine the manner in which timely delivery of his bid will be accomplished either in person, by messenger or by mail.

IB.22 Modification, Substitution and Withdrawal of Bids

- 22.1 Any bidder may modify, substitute or withdraw his bid after bid submission provided that the modification, substitution or written notice of withdrawal is received by the Procuring Entity prior to the deadline or the extended deadline pursuant to clause IB.20.2, for submission of bids.
- 22.2 The modification, substitution or notice for withdrawal of any bid shall be prepared, sealed, marked and delivered in accordance with the provisions of Clause IB.19 with the outer and inner envelopes additionally marked "MODIFICATION", "SUBSTITUTION" or "WITHDRAWAL" as appropriate.
- 22.3 No bid may be modified by a bidder after the deadline for submission of bids except in accordance with Sub-Clauses 22.1 and 27.2.
- 22.4 Withdrawal of a bid during the interval between the deadline for submission of bids and the expiration of the period of bid validity specified in the Form of Bid may result in forfeiture of the Bid Security in pursuance to Clause IB.15.

E. BID OPENING AND

EVALUATION

IB.23 Bid Opening

- 23.1 The Procuring Entity will open all the bids received (except those received late), including withdrawals, substitution and modifications made pursuant to Clause IB.22, in the presence of bidders' or their representatives who choose to attend, at the time, date and location stipulated in the Bidding Data/Title page/NIT. In the event of the specified date for the opening of bids being declared a holiday for the Procuring Entity, the Bids will be opened at the appointed time and location on the next working day.
- 23.2 Envelopes marked "MODIFICATION", "SUBSTITUTION" or "WITHDRAWAL" shall be opened and read out first. Bids for which an acceptable notice of withdrawal has been submitted pursuant to Clause IB.22 shall not be opened.
- 23.3 The bidder's name, total Bid Price and price of any Alternate Proposal(s), any discounts, bid modifications, substitution and withdrawals, the presence or absence of Bid Security and such other details as the Procuring Entity may consider appropriate, will be announced by the Procuring Entity at the opening of bids.

- 23.4 Procuring Entity may prepare minutes of the bid opening including the information disclosed to those present in accordance with the Sub-Clause 23.3.

IB.24 Process to be Confidential

- 24.1 Information relating to the examination, clarification, evaluation and comparison of bid and recommendations for the award of a contract shall not be disclosed to bidders or any other person not officially concerned with such process before the announcement of the final result of the bid evaluation which may be done at least ten (10) days prior to issue of Letter of Acceptance and place the same on its and Authority's Website (KP-PPRA Rule-45). The announcement to all Bidders will include Comparative Statements and recommendations against all the bids evaluated. Any effort by a bidder to influence the Procuring Entity's processing of bids or award decisions may result in the rejection of such bidder's bid. Whereas any bidder feeling aggrieved may lodge a written complaint not later than fifteen (15) days after the announcement of the bid evaluation report; however mere fact of lodging a complaint shall not warrant suspension of the procurement process.

IB.25 Clarification of Bids

- 25.1 To assist in the examination, evaluation and comparison of bids, the Procuring Entity may, at his discretion, ask any bidder for clarification of his bid, including breakdowns of unit rates. The request for clarification and the response shall be in writing but no change in the premium/price or substance of the bid shall be sought, offered or permitted except as required to confirm the correction of arithmetic errors discovered by the Procuring Entity in the evaluation of the bids in accordance with Clause IB.28.

IB.26 Examination of Bids and Determination of Responsiveness

- 26.1 Prior to the detailed evaluation of bids, the Procuring Entity will determine whether each bid is substantially responsive to the requirements of the Bidding Documents.
- 26.2 A substantially responsive bid is one which (i) meets the eligibility criteria; (ii) has been properly signed; (iii) is accompanied by the required Bid Security and (iv) conforms to all the terms, conditions and specifications of the Bidding Documents, without material deviation or reservation. A material deviation or reservation is one (i) which affect in any substantial way the scope, quality or performance of the Works; (ii) which limits in any substantial way, inconsistent with the Bidding Documents, the Procuring Entity's rights or the bidder's obligations under the Contract; or (iii) adoption/rectification whereof would affect unfairly the competitive position of other bidders presenting substantially responsive bids.

- 26.3 If a bid is not substantially responsive, it will be rejected by the Procuring Entity and may not subsequently be made responsive by correction or withdrawal of the non-conforming deviation or reservation.

IB.27 Correction of Errors

- 27.1 Bids determined to be substantially responsive will be checked by the Procuring Entity for any arithmetic errors. Errors will be corrected by the Procuring Entity as follows:
- (a) where there is a discrepancy between the amounts in figures and in words, the amount in words will govern and
 - (b) where there is a discrepancy between the unit rate and the line item total resulting from multiplying the unit rate by the quantity, the unit rate as quoted will govern, unless in the opinion of the Procuring Entity there is an obviously gross misplacement of the decimal point in the unit rate, in which case the line item total as quoted will govern and the unit rate will be corrected.
- 27.2 The amount stated in the Form of Bid will be adjusted by the Procuring Entity in accordance with the above procedure for the correction of errors and with the concurrence of the bidder, shall be considered as binding upon the bidder. If the bidder does not accept the corrected bid price, his bid will be rejected and the Bid Security shall be forfeited in accordance with Sub-Clause 15.6(b) hereof.

IB.28 Evaluation and Comparison of Bids

- 28.1 The Procuring Entity will evaluate and compare only the bids determined to be substantially responsive in accordance with Clause IB.26.
- 28.2 In evaluating the bids, the Procuring Entity will determine for each bid the evaluated Bid Price by adjusting the Bid Price as follows:
- (a) making any correction for errors pursuant to Clause IB.27;
 - (b) excluding Provisional Sums and the provision, if any, for contingencies in the Summary Bill of Quantities, but including competitively priced Day work; and
 - (c) making an appropriate adjustment for any other acceptable variation or deviation, including discounts or other price modification in the bids.
- 28.3 The estimated effect of the price adjustment provisions of the Conditions of Contract, applied over the period of execution of the Contract, shall not be taken into account in Bid evaluation.

- 28.4 If the Bid of the successful bidder is seriously unbalanced in relation to the Procuring Entity's estimate of the cost of work to be performed under the Contract, the Procuring Entity may require the bidder to produce detailed price analyses for any or all items of the Bill of Quantities to demonstrate the internal consistency of those prices with the construction methods and schedule proposed. After evaluation of the price analyses, the Procuring Entity may require that the amount of the Performance Security set forth in Clause IB.32 be increased at the expense of the successful bidder to a level sufficient to protect the Procuring Entity against financial loss in the event of default of the successful bidder under the Contract.

F. AWARD OF CONTRACT

IB.29 Award

- 29.1 Subject to Clauses IB.30 and IB.34, the Procuring Entity will award the Contract to the bidder whose bid has been determined to be substantially responsive to the Bidding Documents and who has offered the lowest evaluated Bid Price, provided that such bidder has been determined to be eligible in accordance with the provisions of Clause IB.3 and qualify pursuant to Sub-Clause IB 29.2.
- 29.2 The Procuring Entity, at any stage of the bid evaluation, having credible reasons for or *prima facie* evidence of any defect in supplier's or contractor's capacities, may require the suppliers or contractors to provide information concerning their professional, technical, financial, legal or managerial competence whether already pre-qualified or not:

Provided that such qualification shall only be laid down after recording reasons therefore in writing. They shall form part of the records of that bid evaluation report.

IB.30 Procuring Entity's Right to Accept any Bid and to Reject any or all Bids

- 30.1 Notwithstanding Clause IB.29, the Procuring Entity reserves the right to accept or reject any Bid, and to annul the bidding process and reject all bids, at any time prior to award of Contract, without thereby incurring any liability to the affected bidders or any obligation except that the grounds for rejection of all bids shall upon request be communicated to any bidder who submitted a bid, without justification of grounds. Rejection of all bids shall be notified to all bidders promptly.

IB.31 Notification of Award

- 31.1 Prior to expiration of the period of bid validity prescribed by the Procuring Entity, the Procuring Entity will notify the successful bidder in writing (“Letter of Acceptance”) that his Bid has been accepted. This letter shall name the sum which the Procuring Entity will pay the Contractor in consideration of the execution and completion of the Works by the Contractor as prescribed by the Contract (hereinafter and in the Conditions of Contract called the “Contract Price”).
- 31.2 No Negotiation with the bidder having evaluated as lowest responsive or any other bidder shall be permitted, however, Procuring Entity may have clarification meetings to get clarification of any item in the bid evaluation report.
- 31.3 The notification of award and its acceptance by the bidder will constitute the formation of the Contract, binding the Procuring Entity and the bidder till signing of the formal Contract Agreement.

IB.32 Performance Security (As Per KPPA Rules 2014)

- 32.1 The successful bidder shall furnish to the Procuring Entity a Performance Security in the form and the amount stipulated in the Bidding Data and the Conditions of Contract plus additional security for unbalanced bids in accordance with Clause IB.28.4 within a period of 28 days after the receipt of Letter of Acceptance.
- 32.2 Failure of the successful bidder to comply with the requirements of Sub-Clause IB.32.1 or Clauses IB.33 or IB.35 shall constitute sufficient grounds for the annulment of the award and forfeiture of the Bid Security.

IB.33 Signing of Contract Agreement

- 33.1 Within 14 days from the date of furnishing of acceptable Performance Security under the Conditions of Contract, the Procuring Entity will send the successful bidder the Contract Agreement in the form provided in the Bidding Documents, incorporating all agreements between the parties.
- 33.2 The formal Agreement between the Procuring Entity and the successful bidder shall be executed within 14 days of the receipt of the Contract Agreement by the successful bidder from the Procuring Entity.

IB.34 General Performance of the Bidders

The Procuring Entity reserves the right to obtain information regarding performance of the bidders on their previously awarded contracts/works. The Procuring Entity may in case of consistent poor performance of any Bidder as reported by the Procuring Entity's of the previously awarded contracts, inter alia, reject his bid and/or refer the case to the Pakistan Engineering Council (PEC) and KPPRA. Upon such reference, PEC / K P P R A in accordance with its rules, procedures and relevant laws of the land take such action as may be deemed appropriate under the circumstances of the case including black listing of such Bidder and debarring him from participation in future bidding for similar works.

IB.35 Integrity Pact

The Bidder shall sign and stamp the Integrity Pact provided at Appendix-L to Bid in the Bidding Documents for all procurement contracts exceeding Rupees ten million. Failure to provide such Integrity Pact shall make the bidder non- responsive.

IB.36 Instructions not Part of Contract

Bids shall be prepared and submitted in accordance with these Instructions which are provided to assist bidders in preparing their bids, and do not constitute part of the Bid or the Contract Documents.

BIDDING DATA

Bidding Data

Instructions to Bidders
Clause Reference

1.1 NAME AND ADDRESS OF THE PROCURING ENTITY: EXECUTIVE ENGINEER, CHARSADDA IRRIGATION DIVISION CHARSADDA BEHALF OF CHIEF ENGINEER (SOUTH) IRRIGATION DEPARTMENT.

1.1 Name of the Project:

(Name of Project as per NIT)

Developmental as per title page/NIT. This document applies to each sub work separately as tabulated in the title page/NIT

2.1 Name of the Borrower/Source of Financing/Funding Agency:

As per title page/NIT ADP

8.1 Time limit for clarification:

[Minimum number of days to seek clarification by the prospective bidder may be inserted as 07 days.]

10.1 Bid language:

English

11.1 (b) Prequalification Information to be updated:

Enlistment with Irrigation Department have valid E-bidding system login/password, Registration with PEC in the relevant category (As Per NIT) and financial limit, Registration with KPRA (As per KPPRA Bid Solicitation Documents)

11.1(c) Furnish Technical Proposal:

The bidder may submit a technical proposal in sufficient detail to demonstrate the adequacy of the bid in meeting requirements for timely completion of the Works (where applicable)

13.1 *Bidders to quote entirely in Pak. Rupees on above/below premium on E-bidding system for each sub work separately*

14.1 Period of Bid Validity:

90 days

15.1 Amount of Bid Security:

2% of Estimated Cost

Notified as per KPPRA vide Notification No. S.R.O. (14)/Vol: 1-24/2021-22:, Dated Peshawar, the 10th May 2022 /6058-71.

17.1 Venue, time, and date of the pre-Bid meeting:

*Office of the Executive Engineer Charsadda Irrigation Division Charsadda,
Phone No. 091-6514641, Email:charsaddairrigation@yahool.com mentioned in the
NIT*

18.4 Number of copies of the Bid to be completed and returned:

one original & complete

19.2(a) Procuring Entity's address for the purpose of Bid submission:

As mentioned in the NIT

*Office of the Executive Engineer, Charsadda Irrigation Division Charsadda,
Phone No. 091-6514641, Email:charsaddairrigation@yahool.com mentioned in the
NIT*

19.2(b) Name and Number of the Contract:

As per title page/NIT for each sub work as hand written on each document

20.1(a) Deadline for submission of bids:

As per NIT

23.1 Venue, time, and date of Bid opening:

*Office of the Executive Engineer Charsadda Irrigation Division Charsadda,
Phone No. 091-6514641, Email:charsaddairrigation@yahool.com mentioned in the
NIT*

32.1 Standard form and amount of Performance Security acceptable to the Procuring Entity:

(As per KPPRA Rules 2014).

**FORM OF BID
AND
APPENDICES TO BID**

FORM OF BID

Bid Reference No. _____
 NIT No. _____
 Date of Opening No. _____
 Work No. as per NIT. _____

To:

Executive Engineer,
 Charsadda Irrigation Division,
 Charsadda.

Gentleman,

1. Having examined the Bidding Documents including Instructions to Bidders, Bidding Data, Conditions of Contract. Specifications, Drawings and Bill of Quantities and Addenda Nos. _____ for the execution of the above-named Works, we, the undersigned, offer to execute and complete such Works and remedy any defects therein in conformity with the Conditions of Contract. Specifications, Drawings, Bill of Quantities and Addenda for the sum of Rs. (Rupees _____) or such other sum as may be ascertained in accordance with the said conditions.
2. We understand that all the Appendices attached hereto form part of this Bid.
3. As security for due performance of the undertakings and obligations of this Bid, we submit herewith a Bid Security in the amount of Rupees _____ (Rs. _____) drawn in your favour or made payable to you and valid for a period of _____ days beginning from the date Bids are opened.
4. We undertake, if our Bid is accepted, to commence the Works and to complete the whole of the Works comprised in the Contract within the time stated in Appendix-A to Bid.
5. We agree to abide by this Bid for the period of _____ days from the date fixed for receiving the same and it shall remain binding upon us and may be accepted at any time before the expiration of that period.
6. Unless and until a formal Agreement is prepared and executed, this Bid, together with your written acceptance thereof, shall constitute a binding contract between us.
7. We do hereby declare that the Bid is made without any collusion, comparison of figures or arrangement with any other bidder for the Works.

8. We understand that you are not bound to accept the lowest or any Bid you may receive.

Dated this _____ day of _____ 20 _____

Signature: _____

in the capacity of _____ duly authorized to sign Bids for and on behalf of

(Name of Bidder in Block Capitals)
(Seal)

Address: _____

Witness:

Signature: _____

Name: _____

Address. _____

Occupation _____

SPECIAL STIPULATIONS

Clause

Conditions of Contract

1.	Engineer's Authority to issue Variation in Emergency	2.1	15% of the Contract Price stated in the Letter of Acceptance. (as per KPPRA Rules 2014)
2.	Amount of Performance Security	IB.32	<i>As per KPPRA Rules 2014</i>
3.	Time for Furnishing Program	14.1	Within 28 days from the date of receipt of Letter of Acceptance.
4.	Minimum amount of Third Party Insurance	23.2	Not Applicable
5.	Time for Commencement	41.1	Within 14 days from the date of receipt of Engineer's Notice to Commence which shall be issued within fourteen (14) days after signing of Contract Agreement.
6.	Time for Completion	43.1 48.2	As per work order
7.	a) Amount of Liquidated Damages	47.1	Rs. 0.05% of E/C for each day of delay in completion of the Works subject to a maximum of 10% of Contract Price stated in the Letter of Acceptance.
	b) Amount of Bonus	47.3	N/A
8.	Defects Liability Period	49.1	365 _____ days from the effective date of Taking Over Certificate.
9.	Percentage of Retention Money	60.2	8 % of the amount of Interim Payment Certificate.
10.	Limit of Retention Money	60.2	[8 %]⁺ of Contract Price stated in the Letter of acceptance.
11.	Minimum amount of Interim Payment Certificates (Running Bills)	60.2	Rs. (No limit within contract cost, as per available funds, work importance & work done
12.	Time of Payment from delivery of Engineer's Interim Payment Certificate to the Procuring	60.10	After release of funds and verification of work as per specification and due consideration of other works in the head and importance of each work (DDO Decision)
13.	Mobilization Advance [* (Interest Free)]^p	60.12	Not Applicable

* **Delete if alternative one is not adopted.**

FOREIGN CURRENCY REQUIREMENTS
(NOT APPLICABLE)

1. The Bidder may indicate herein below his requirements of foreign currency (if any), with reference to various inputs to the Works.
2. Foreign Currency Requirement as percentage of the Bid Price excluding Provisional Sums _____%.
3. Table of Exchange Rates

Unit of Currency	Equivalent in Pak. Rupees
Australian Dollar	-----
Euro	-----
Japanese Yen	-----
U.K. Pound	-----
U.S. Dollars	-----
-----	-----
-----	-----

NOT TO BE

**PRICE ADJUSTMENT UNDER CLAUSE 70
OF CONDITIONS OF CONTRACT
(NOT APPLICABLE)**

The source of indices and the weightages or coefficients for use in the adjustment formula under Clause 70 shall be as follows:

(To be filled by the Procuring Entity).

Cost Element	Description	Weightages	Applicable index
1	2	3	4
(i)	Fixed Portion	0.350	
(ii)	Local Labour		Government of Pakistan (GP) Federal Bureau of Statistics (FBS) Monthly Statistical Bulletin.
(iii)	Cement – in bags		“ “ “
(iv)	Reinforcing Steel		“ “ “
(v)	High Speed Diesel (HSD)		“ “ “
(vi)	Bricks		“ “ “
(vii)	Bitumen		“ “ “
(viii)			
	Total	1.000	

Notes:

- 1) Indices for “(ii)” to “(vii)” are taken from the Government of Pakistan Federal Bureau of Statistics, Monthly Statistical Bulletin. The base cost indices or prices shall be those applying 28 days prior to the latest day for submission of bids. Current indices or prices shall be those applying 28 days prior to the last day of the billing period.
- 2) Any fluctuation in the indices or prices of materials other than those given above shall not be subject to adjustment of the Contract Price.
- 3) Fixed portion shown here is for typical road project, Procuring Entity to determine the weightage of Fixed Portion considering only those cost elements having cost impact of seven (7) percent or more on his specific project.

(Procuring Entity’s using this price adjustment provisions may add or delete any elements as deemed appropriate to the project.)

BILL OF QUANTITIES

BILL OF QUANTITIES

THE BOQ SHALL BE FILLED ONLINE ON IRRIGATION DEPARTMENT WEBSITE, THE PROCURING ENTITY SHALL NOT BE LIABLE FOR THE ERRORS/MALFUNCTIONS OF THE E-BIDDING SYSTEM, LOSS OR NON-PROVISION OF EBIDDING SYSTEM LOGIN & PASSWORD

<http://www.irrigation.gkp.pk>

OR

<http://www.irrigation.gkp.pk/tenders.php>



Irrigation Department

Government of Khyber Pakhtunkhwa

BILL OF QUANTITIES

Estimated Cost:	100.4941	Reference #:	REF-4553123	Print Date:	23-05-2022
MRS Year:	2022	Area Factor:	1.000	Tax Factor	0.000
Work Name:	210455-Construction of flood protections works, irrigation channels and ponds and installation of solar irrigation tube wells in Khyber Pakhtunkhwa ADP No.2267 during 2021-22. Sub Work:- Construction /up-gradation of Tatono bridge (dot-17) on Main lower Swat Canal District Charsadda.				

General Abstract of Cost

S.No.	Description	Amount
1	Schedule Amount	100.4941
2	Non Schedule Amount	0.0000
	Total	100.4941 Millions

General Abstract of Cost (Head Wise)

S.No.	Description	Amount
1	210455-Construction of flood protection works, irrigation channels and ponds and installation of solar irrigation tube wells in Khyber Pakhtunkhwa ADP No.2267, during 2021-22.	100,494,100.8597
	Sub Total:	100.4941 Millions
	Grand Total with Area Factor: 1.000 Tax Factor: 0.000	100.4941 Millions

General Abstract of Cost (Sub Head Wise)

S.No.	Description	Amount
1	Construction / upgradation of Tatono Bridge (Dot-17) on Main Lower Swat Canal District Charsadda.	100,494,100.8597
	Sub Total:	100.4941 Millions
	Grand Total with Area Factor: 1.000 Tax Factor: 0.000	100.4941 Millions

BILL OF QUANTITIES (B.O.Q)

S.No.	Item Code	Item Name	Unit	Qty	Price	Total
Construction / upgradation of Tatono Bridge (Dot-17) on Main Lower Swat Canal District Charsadda.						
1	08-01-d-03	Random rubble masonry in foundn. & plinth in cement, sand mortar : Ratio 1:6	m3	214.08	7,554.1500	1617192.432
2	16-86-d	Galvanized Sheath for 10 to 12 Wires 0.5" Strand Cable	m	2160.00	607.4200	1312027.2
3	16-85-a	Supply of High Tensile Pre-stressed concrete steel wire strand Grade 270K 0.5" dia. Packed in standard reeless/weldless coils of two 2000 kgs approximately binded and wraped in Hessian Cloth.	m	17.73	350,597.1900	6216088.1787
4	16-83-c	Jack Anchorage For 10 to 12 Wires 0.5" Strand (Comprising Trumpet, Stressing Block & Wedges Complete)	m	80.00	8,593.7100	687496.8
5	16-65	Providing and Laying PVC pipe (b) 8" dia in foot path of bridge for utilities.	m2	573.70	2,075.1600	1190519.292
6	16-57	Supply and Fixing polystrene fill in expansion joints & under diaphragms at transoms.	m2	0.89	3,617.3200	3219.4148
7	16-55	Supply and place in position galvanised steel 3" dia drain scuppers in deck slab as per specs/drwg	m2	140.00	538.9400	75451.6
8	16-54	Supply and place in position MS expansion joint assemblies as specified & as per drawing	m2	890.00	264.8000	235672
9	16-53	Cut off projecting wire ends of cables & make good anchorage recess with 1:2:4 cem. conc.	m2	160.00	807.4800	129196.8
10	16-46	Inject Cement Grout in Sheath Pipe after stressing	Each	2160.00	60.2500	130140

S.No.	Item Code	Item Name	Unit	Qty	Price	Total
11	16-42	Stressing Cable of High Tensile Steel Wire Strands	Each	80.00	1,581.1200	126489.6
12	16-41	Launching girders in place, including lifting & handling if any	Each	540.00	2,953.8400	1595073.6
13	16-38-a	Supply and Fixing Neoprene Bearing Pad as per specs & design	m	450000.00	4.0900	1840500
14	16-66	Providing and filling sand behind abutment of bridges, culverts.	m3	1060.19	1,965.1200	2083400.5728
15	16-14-b	Asphaltic Wearing Course (Asphalt Batch Plant Hot Mixed) i/c Transportation and Finishing complete	each	248.19	22,800.7800	5658925.5882
16	16-14-a	Asphaltic Base Course (Asphalt Batch Plant Hot Mixed) i/c Transportation and Finishing complete	Each	217.81	19,809.4200	4314689.7702
17	16-09-b	Bitumenous Tack Coat	m2	4905.28	69.9600	343173.3888
18	16-09-a	Bitumenous Prime Coat	m2	2858.44	217.4800	621653.5312
19	16-05-b	Water Bound Macadam Base Course	m2	653.44	2,621.5800	1713045.2352
20	16-04-a	Granular Sub Base Course using Pit Run Gravel	Each	871.26	1,582.2000	1378507.572
21	19-26	Supplying stone and stone filling in GI wire crate and its sewing, excluding cost of crates	m3	1902.90	2,602.0400	4951421.916
22	19-13-a-03	Provide & weave GI wire netting for wire crates 6"x9" mesh : 8 SWG wire	m2	7640.34	529.6000	4046324.064
23	03-70-c	Formation of Embankment from Borrow Excavation in Common Material including compaction Modified AASHTO 90% by power roller.	m3	4704.79	662.3800	3116358.8002

S.No.	Item Code	Item Name	Unit	Qty	Price	Total
24	03-19-a	Extra for every 15 m extra lead or part thereof for earthwork soft, ordinary, hard & very hard	m3	55699.22	5.6100	312472.6242
25	03-19-a	Extra for every 15 m extra lead or part thereof for earthwork soft, ordinary, hard & very hard	m3	55699.22	5.6100	312472.6242
26	03-19-a	Extra for every 15 m extra lead or part thereof for earthwork soft, ordinary, hard & very hard	m3	55699.22	5.6100	312472.6242
27	03-19-a	Extra for every 15 m extra lead or part thereof for earthwork soft, ordinary, hard & very hard	m3	55699.22	5.6100	312472.6242
28	03-19-a	Extra for every 15 m extra lead or part thereof for earthwork soft, ordinary, hard & very hard	m3	55699.22	5.6100	312472.6242
29	03-19-a	Extra for every 15 m extra lead or part thereof for earthwork soft, ordinary, hard & very hard	m3	55699.22	5.6100	312472.6242
30	03-19-a	Extra for every 15 m extra lead or part thereof for earthwork soft, ordinary, hard & very hard	m3	55699.22	5.6100	312472.6242
31	03-19-a	Extra for every 15 m extra lead or part thereof for earthwork soft, ordinary, hard & very hard	m3	55699.22	5.6100	312472.6242
32	03-19-a	Extra for every 15 m extra lead or part thereof for earthwork soft, ordinary, hard & very hard	m3	55699.22	5.6100	312472.6242
33	03-19-a	Extra for every 15 m extra lead or part thereof for earthwork soft, ordinary, hard & very hard	m3	55699.22	5.6100	312472.6242
34	03-19-a	Extra for every 15 m extra lead or part thereof for earthwork soft, ordinary, hard & very hard	m3	55699.22	5.6100	312472.6242

S.No.	Item Code	Item Name	Unit	Qty	Price	Total
35	03-19-a	Extra for every 15 m extra lead or part thereof for earthwork soft, ordinary, hard & very hard	m3	55699.22	5.6100	312472.6242
36	03-19-a	Extra for every 15 m extra lead or part thereof for earthwork soft, ordinary, hard & very hard	m3	55699.22	5.6100	312472.6242
37	03-19-a	Extra for every 15 m extra lead or part thereof for earthwork soft, ordinary, hard & very hard	m3	55699.22	5.6100	312472.6242
38	03-19-a	Extra for every 15 m extra lead or part thereof for earthwork soft, ordinary, hard & very hard	m3	55699.22	5.6100	312472.6242
39	03-72-b	Earthwork by mechanical means in drains and irrigation channels in DRY & WET soil dressed to designed section, grades profile/with excavated material, disposed off within 50 feet (15.2 m) lead and dressed as directed.	m3	111506.37	71.8700	8013962.8119
40	06-08-b	Supply & fabricate M.S. reinforcement for cement concrete (Hot rolled deformed bars Grade 60)	Tonne	42.10	242,684.0900	10217000.189
41	06-07-c-01	RCC including Precast/Prestressed in slab, beam, column, lintel, girder, etc. (1:1:2)	m3	388.53	14,795.3000	5748417.909
42	06-07-a-03	RCC in roof slab, beam, column & other structural members, insitu or precast. (1:2:4)	m3	207.33	11,062.4500	2293577.7585
43	06-46-b	Erection and removal of Form work with Wood Surface Finshing for RCC or Plain cement Concrete in any shape - Position / Vertical	m2	3334.85	640.2300	2135071.0155
44	06-44-c	PCC 1:3:6 in mass concrete less formwork using 30% boulders	m3	2541.17	6,416.0700	16304324.6019
45	06-05-i	Plain Cement Concrete including placing, compacting, finishing & curing (Ratio 1:4:8)	m3	116.79	7,002.5300	817825.4787

S.No.	Item Code	Item Name	Unit	Qty	Price	Total
46	06-05-h	Plain Cement Concrete including placing, compacting, finishing & curing (Ratio 1:3:6)	m3	36.22	7,806.5300	282752.5166
47	06-08-c	Supply & fabricate M.S. reinforcement for cement concrete (Hot rolled deformed bars Grade 40)	Tonne	28.07	235,394.0900	6607512.1063
					Sub Total:	100.4941 Millions
					Grand Total with Area Factor: 1.000 Tax Factor: 0.000	100.4941 Millions

B.O.Q

Appendix-E to Bid

PROPOSED CONSTRUCTION SCHEDULE

Pursuant to Sub-Clause 43.1 of the General Conditions of Contract, the Works may be completed on or before the date stated in Appendix-A to Bid. The Bidder may provide as Appendix-E to Bid, the Construction Schedule in the bar chart (CPM, PERT or any other to be specified herein) showing the sequence of work items and the period of time during which he proposes to complete each work item in such a manner that his proposed program for completion of the whole of the Works and parts of the Works may meet Procuring Entity's completion targets in days noted below and counted from the date of receipt of Engineer's Notice to Commence (Attach sheets as required for the specified form of Construction Schedule):

<u>Description</u>	<u>Time for Completion</u>
a) Whole Works	_____ days
b) Part-A	_____ days
c) Part-B	_____ days
d) _____	_____ days
e) _____	_____ days

Signature: _____

Seal: _____

Dated: _____

Appendix-F to Bid

METHOD OF PERFORMING THE WORK

The Bidder may submit a narrative outlining the method of performing the Work.
The narrative should indicate in detail and include but not be limited to:

1. Organization Chart indicating head office and field office personnel involved in management and supervision, engineering, equipment maintenance and purchasing.
2. Mobilization in Pakistan, the type of facilities including personnel accommodation, office accommodation, provision for maintenance and for storage, communications, security and other services to be used.
3. The method of executing the Works, the procedures for installation of equipment and machinery and transportation of equipment and materials to the site.
4. The bidder work at site will be executed through a PEC registered Engineer.

Signature: _____

Seal: _____

Dated: _____

Appendix-G to Bid

LIST OF MAJOR EQUIPMENT – RELATED ITEMS

The Bidder may provide on Sheet 2 of this Appendix a list of all major equipment and related items, under separate heading for items owned, to be purchased or to be arranged on lease by him to carry out the Works. The information shall include make, type, capacity, and anticipated period of utilization for all equipment which shall be in sufficient detail to demonstrate fully that the equipment will meet all requirements of the Specifications.

Note: Machinery for the construction works will be asked for from Mechanical Irrigation Division, in case of non-availability NOC from the concerned Division shall be obtained.

Signature: _____

Seal: _____

Dated: _____

Appendix-G to Bid

LIST OF MAJOR EQUIPMENT

Owned Purchased or Leased	Description of Unit (Make, Model, Year)	Capacity HP Rating	Condition	Present Location or Source	Date of Delivery at Site	Period of Work on Project
1	2	3	4	5	6	7
a. Owned						
b. To be Purchased						
c. To be arranged on Lease						

Note: Machinery for the construction works shall be obtained firstly from the Mechanical Irrigation Division. In case of non-availability, NOC from that office shall be obtained.

Appendix-J to Bid

**ESTIMATED PROGRESS PAYMENTS
(SUBJECT TO AVAILABILITY OF FUNDS, WORK DONE, IMPORTANCE)**

Bidder' estimate of the value of work which would be executed by him during each of the periods stated below, based on his Program of the Works and the Rates in the Bill of Quantities, expressed in thousands of Pakistani Rupees:

Quarter/ Year/ Period	Amounts (1,000 Rs.)
1	2
Ist Quarter	
2 nd Quarter	
3 rd Quarter	
4 th Quarter	
5 th Quarter	
6 th Quarter	
7 th Quarter	
8 th Quarter	
9 th Quarter	
Bid Price	

Signature: _____

Seal: _____

Dated: _____

BK-1

Appendix-K to Bid

**ORGANIZATION CHART
FOR THE
SUPERVISORY STAFF AND LABOUR**

(INTEGRITY PACT)

**DECLARATION OF FEES, COMMISSION AND BROKERAGE ETC.
PAID BY THE SUPPLIERS OF GOODS, SERVICES & WORKS IN
CONTRACTS WORTH RS. 10.00 MILLION OR MORE**

Contract No. _____ Dated _____
Contract Value: _____
Contract Title: _____

..... [name of Supplier] hereby declares that it has not obtained or induced the procurement of any contract, right, interest, privilege or other obligation or benefit from Government of Pakistan (GoP) or any administrative subdivision or agency thereof or any other entity owned or controlled by GoP through any corrupt business practice.

Without limiting the generality of the foregoing, [name of Supplier] represents and warrants that it has fully declared the brokerage, commission, fees etc. paid or payable to anyone and not given or agreed to give and shall not give or agree to give to anyone within or outside Pakistan either directly or indirectly through any natural or juridical person, including its affiliate, agent, associate, broker, consultant, director, promoter, shareholder, sponsor or subsidiary, any commission, gratification, bribe, finder's fee or kickback, whether described as consultation fee or otherwise, with the object of obtaining or inducing the procurement of a contract, right, interest, privilege or other obligation or benefit in whatsoever form from GoP, except that which has been expressly declared pursuant hereto.

[name of Supplier] certifies that it has made and will make full disclosure of all agreements and arrangements with all persons in respect of or related to the transaction with GoP and has not taken any action or will not take any action to circumvent the above declaration, representation or warranty.

[name of Supplier] accepts full responsibility and strict liability for making any false declaration, not making full disclosure, misrepresenting facts or taking any action likely to defeat the purpose of this declaration, representation and warranty. It agrees that any contract, right, interest, privilege or other obligation or benefit obtained or procured as aforesaid shall, without prejudice to any other rights and remedies available to GoP under any law, contract or other instrument, be voidable at the option of GoP.

Notwithstanding any rights and remedies exercised by GoP in this regard, [name of Supplier] agrees to indemnify GoP for any loss or damage incurred by it on account of its corrupt business practices and further pay compensation to GoP in an amount equivalent to ten times the sum of any commission, gratification, bribe, finder's fee or kickback given by [name of Supplier] as aforesaid for the purpose of obtaining or inducing the procurement of any contract, right, interest, privilege or other obligation or benefit in whatsoever form from GoP.

Name of Buyer:
Signature:
[Seal]

Name of Seller/Supplier:
Signature:
[Seal]

FORMS

**BID SECURITY
PERFORMANCE SECURITY
CONTRACT AGREEMENT
MOBILIZATION ADVANCE GUARANTEE/BOND**

BID SECURITY
(Bank Guarantee)

Security Executed on _____
(Date)

Name of Surety (Bank) with Address: _____
(Scheduled Bank in Pakistan)

Name of Principal (Bidder) with Address _____

Penal Sum of Security Rupees . _____ (Rs. _____)

Bid Reference No. _____

KNOW ALL MEN BY THESE PRESENTS, that in pursuance of the terms of the Bid and at the request of the said Principal (Bidder) we, the Surety above named, are held and firmly bound unto _____

(hereinafter called the 'Procuring Entity') in the sum stated above for the payment of which sum well and truly to be made, we bind ourselves, our heirs, executors, administrators and successors, jointly and severally, firmly by these presents.

THE CONDITION OF THIS OBLIGATION IS SUCH, that whereas the Bidder has submitted the accompanying Bid dated _____ for Bid No. _____ for _____ (Particulars of Bid) to the said Procuring Entity; and

WHEREAS, the Procuring Entity has required as a condition for considering said Bid that the Bidder furnishes a Bid Security in the above said sum from a Scheduled Bank in Pakistan or from a foreign bank duly counter-guaranteed by a Scheduled Bank in Pakistan, to the Procuring Entity, conditioned as under:

- (1) that the Bid Security shall remain in force up to and including the date 28 days after the deadline for validity of bids as stated in the Instructions to Bidders or as it may be extended by the Procuring Entity, notice of which extension(s) to the Surety is hereby waived;
- (2) that the Bid Security of unsuccessful Bidders will be returned by the Procuring Entity after expiry of its validity or upon signing of the Contract Agreement; and
- (3) that in the event of failure of the successful Bidder to execute the proposed Contract Agreement for such work and furnish the required Performance Security, the entire said sum be paid immediately to the said Procuring Entity pursuant to Clause 15.6 of the Instruction to Bidders for the successful Bidder's failure to perform.

NOW THEREFORE, if the successful Bidder shall, within the period specified therefor, on the prescribed form presented to him for signature enter into a formal Contract with the said Procuring Entity in accordance with his Bid as accepted and furnish within twenty eight (28) days of his being requested to do so, a Performance Security with good and sufficient surety, as may be required, upon the form prescribed by the said Procuring Entity for the faithful performance and proper fulfillment of the said Contract or in the event of non-withdrawal of the said Bid within the time specified for its validity then this obligation shall be void and of no effect, but otherwise to remain in full force and effect.

PROVIDED THAT the Surety shall forthwith pay the Procuring Entity the said sum upon first written demand of the Procuring Entity (without cavil or argument) and without requiring the Procuring Entity to prove or to show grounds or reasons for such demand, notice of which shall be sent by the Procuring Entity by registered post duly addressed to the Surety at its address given above.

PROVIDED ALSO THAT the Procuring Entity shall be the sole and final judge for deciding whether the Principal (Bidder) has duly performed his obligations to sign the Contract Agreement and to furnish the requisite Performance Security within the time stated above, or has defaulted in fulfilling said requirements and the Surety shall pay without objection the said sum upon demand from the Procuring Entity forthwith and without any reference to the Principal (Bidder) or any other person.

IN WITNESS WHEREOF, the above bounden Surety has executed the instrument under its seal on the date indicated above, the name and seal of the Surety being hereto affixed and these presents duly signed by its undersigned representative pursuant to authority of its governing body.

SURETY (Bank)

WITNESS:

Signature _____

1. _____ Name _____

_____ Title _____

Corporate Secretary (Seal)

Corporate Guarantor (Seal)

2. _____

Name, Title & Address

**FORM OF PERFORMANCE SECURITY
(Bank Guarantee)**

Guarantee No. _____
Executed on _____
Expiry date _____

[Letter by the Guarantor to the Procuring Entity]

Name of Guarantor (Bank) with address: _____
(Scheduled Bank in Pakistan)

Name of Principal (Contractor) with address: _____

Penal Sum of Security (express in words and figures) _____

Letter of Acceptance No. _____ Dated _____

KNOW ALL MEN BY THESE PRESENTS, that in pursuance of the terms of the Bidding Documents and above said Letter of Acceptance (hereinafter called the Documents) and at the request of the said Principal we, the Guarantor above named, are held and firmly bound unto the (hereinafter called the Procuring Entity) in the penal sum of the amount stated above for the payment of which sum well and truly to be made to the said Procuring Entity, we bind ourselves, our heirs, executors, administrators and successors, jointly and severally, firmly by these presents.

THE CONDITION OF THIS OBLIGATION IS SUCH, that whereas the Principal has the Procuring Entity's above said Letter of Acceptance for (Name of _____ Contract) for the _____ (Name of Project).

NOW THEREFORE, if the Principal (Contractor) shall well and truly perform and fulfill all the undertakings, covenants, terms and conditions of the said Documents during the original terms of the said Documents and any extensions thereof that may be granted by the Procuring Entity, with or without notice to the Guarantor, which notice is, hereby, waived and shall also well and truly perform and fulfill all the undertakings, covenants terms and conditions of the Contract and of any and all modifications of said Documents that may hereafter be made, notice of which modifications to the Guarantor being hereby waived, then, this obligation to be void; otherwise to remain in full force and virtue till all requirements of Clause 49, Defects Liability, of Conditions of Contract are fulfilled.

Our total liability under this Guarantee is limited to the sum stated above and it is a condition of any liability attaching to us under this Guarantee that the claim for payment in writing shall be received by us within the validity period of this Guarantee, failing which we shall be discharged of our liability, if any, under this Guarantee.

We, _____ (the Guarantor), waiving all objections and defences under the Contract, do hereby irrevocably and independently guarantee to pay to the Procuring Entity without delay upon the Procuring Entity's first written demand without cavil or arguments and without requiring the Procuring Entity to prove or to show grounds or reasons for such demand any sum or sums up to the amount stated above, against the Procuring Entity's written declaration that the Principal has refused or failed to perform the obligations under the Contract which payment will be effected by the Guarantor to Procuring Entity's designated Bank & Account Number.

PROVIDED ALSO THAT the Procuring Entity shall be the sole and final judge for deciding whether the Principal (Contractor) has duly performed his obligations under the Contract or has defaulted in fulfilling said obligations and the Guarantor shall pay without objection any sum or sums up to the amount stated above upon first written demand from the Procuring Entity forthwith and without any reference to the Principal or any other person.

IN WITNESS WHEREOF, the above-bounden Guarantor has executed this Instrument under its seal on the date indicated above, the name and corporate seal of the Guarantor being hereto affixed and these presents duly signed by its undersigned representative, pursuant to authority of its governing body.

<p>Witness:</p> <p>1. _____</p> <p>_____</p> <p>Corporate Secretary (Seal)</p> <p>2. _____</p> <p>_____</p> <p>Name, Title & Address</p>	<p>_____</p> <p>Guarantor (Bank)</p> <p>Signature _____</p> <p>Name _____</p> <p>Title _____</p> <p>_____</p> <p>Corporate Guarantor (Seal)</p>
--	---

FORM OF CONTRACT AGREEMENT

THIS CONTRACT AGREEMENT (hereinafter called the "Agreement") made on the _____ day of _____ (month) 20____ between _____ Executive Engineer, Charsadda Irrigation Division Charsadda (hereafter called the "Procuring Entity") Of the one part and _____ (hereafter called the "Contractor") of the other part.

WHEREAS the Procuring Entity is desirous that certain Works, viz _____

_____ should be executed by the Contractor and has accepted a Bid by the Contractor for the execution and completion of such Works and the remedying of any defects therein.

NOW this Agreement witnesseth as follows:

1. In this Agreement words and expressions shall have the same meanings as are respectively assigned to them in the Conditions of Contract hereinafter referred to.
2. The following documents after incorporating addenda, if any, except those parts relating to Instructions to Bidders shall be deemed to form and be read and construed as part of this Agreement, viz:
 - (a) The Contract Agreement;
 - (b) The Letter of Acceptance;
 - (c) The completed Form of Bid;
 - (d) Special Stipulations (Appendix-A to Bid);
 - (e) The Particular Conditions of Contract – Part II;
 - (f) The General Conditions – Part I;
 - (g) The priced Bill of Quantities (Appendix-D to Bid);
 - (h) The completed Appendices to Bid (B, C, E to L);
 - (i) The Drawings;
 - (j) The Specifications.
 - (k) _____ (any other)
3. In consideration of the payments to be made by the Procuring Entity to the Contractor as hereinafter mentioned, the Contractor hereby covenants with the Procuring Entity to execute and complete the Works and remedy defects therein in conformity and in all respects with the provisions of the Contract.
4. The Procuring Entity hereby covenants to pay the Contractor, in consideration of the execution and completion of the Works as per provisions of the Contract, the Contract Price or such other sum as may become payable under the provisions of the Contract at the times and in the manner prescribed by the Contract.

IN WITNESS WHEREOF the parties hereto have caused this Agreement to be executed on the day, month and year first before written in accordance with their respective laws.

Signature of the Contactor

Signature of Procuring Entity

(Seal)

(Seal)

Signed, Sealed and Delivered in the presence of:

Witness:

Witness:

(Name, Title and Address)

(Name, Title and Address)

MOBILIZATION ADVANCE GUARANTEE

Guarantee No. _____ Date _____

WHEREAS _____ (hereinafter called the 'Procuring Entity') has entered into a Contract for _____
 _____ (Particulars of Contract)
 with _____ (hereinafter called the "Contractor").

AND WHEREAS, the Procuring Entity has agreed to advance to the Contractor, at the Contractor's request, an amount of Rupees (Rs) which amount shall be advanced to the Contractor as per provisions of the Contract.

AND WHEREAS, the Procuring Entity has asked the Contractor to furnish Guarantee to secure the mobilization advance for the performance of his obligations under the said Contract.

AND WHEREAS, _____
 _____ (Scheduled Bank in Pakistan acceptable to the Procuring Entity) (hereinafter called the "Guarantor") at the request of the Contractor and in consideration of the Procuring Entity agreeing to make the above advance to the Contractor, has agreed to furnish the said Guarantee.

NOW, THEREFORE, the Guarantor hereby guarantees that the Contractor shall use the advance for the purpose of above mentioned Contract and if he fails and commits default in fulfillment of any of his obligations for which the advance payment is made, the Guarantor shall be liable to the Procuring Entity for payment not exceeding the aforementioned amount.

Notice in writing of any default, of which the Procuring Entity shall be the sole and final judge, on the part of the Contractor, shall be given by the Procuring Entity to the Guarantor, and on such first written demand, payment shall be made by the Guarantor of all sums then due under this Guarantee without any reference to the Contractor and without any objection.

This Guarantee shall remain in force until the advance is fully adjusted against payments from Interim Payment Certificates of the Contractor or until whichever is earlier.

 (Date)

The Guarantor's liability under this Guarantee shall not in any case exceed the sum of Rupees _____ (Rs _____).

This Guarantee shall remain valid up to the aforesaid date and shall be null and void after the aforesaid date or earlier if the advance made to the Contractor is fully adjusted against payments from Interim Payment Certificates of the Contractor provided that the Guarantor agrees that the aforesaid period of validity shall be deemed to be extended if on the above mentioned date the advance payment is not fully adjusted.

GUARANTOR (BANK)

- 1. Signature _____
- 2. Name _____
- 3. Title _____

WITNESS

- 1. _____

Corporate Secretary (Seal)

- 2. _____
(Name Title & Address)
- _____ Corporate Guarantor(Seal)

**Copies of the FIDIC Conditions of Contract
can be obtained by the bidder from: FIDIC
Secretariat P.O. Box 86 1000 Lausanne 12
Switzerland e-mail: fidic.pub@fidic.org –
FIDIC.org/bookshop**



**FEDERATION INTERNATIONALE DES
INGENIEURS-CONSEILS**

**CONDITIONS OF
CONTRACT FOR WORKS OF
CIVIL ENGINEERING
CONSTRUCTION**

**PART I GENERAL CONDITIONS
WITH FORMS OF TENDER AND AGREEMENT**

FOURTH EDITION 1987
Reprinted 1988 with editorial amendments
Reprinted in 1992 with further amendments

Copies of the FIDIC Conditions of Contract 4th Edition, 1987 reprinted in 1992
with further amendments can be obtained from:

FIDIC SECRETARIAT
P.O BOX NO. 86
1000 Lausanne 12
Switzerland

e-mail fidic.pub@fidic.org-FIDIC.org/bookshop

TABLE OF CONTENTS

PART II - PARTICULAR CONDITIONS OF CONTRACT

Clause	Title	Page
1.1	Definitions	147
2.1	Engineer's Duties and Authority	147
2.2	Engineer's Representative	149
2.7	Engineer Not Liable	149
2.8	Replacement of the Engineer	149
5.1	Language(s) and Law	149
5.2	Priority of Contract Documents	149
6.6	Shop Drawings	150
6.7	As-Built Drawings	150
10.1	Performance Security	150
10.4	Performance Security Binding on Variations and Changes	151
14.1	Program to be Submitted	151
14.3	Cash Flow Estimate to be Submitted	151
14.5	Detailed Program and Monthly Progress Report	151
15.2	Language Ability of Contractor's Representative	152
15.3	Contractor's Representative	152
16.3	Language Ability of Superintending Staff of Contractor	152
16.4	Employment of Local Personnel	152
19.3	Safety Precautions	152
19.4	Lighting Works at Night	153
20.4	Procuring Entity's Risks	153
21.1	Insurance of Works and Contractor's Equipment	153
21.4	Exclusions	154
25.5	Insurance Company	154
31.3	Co-operation with Other Contractors	154
34.2	Rates of Wages and Conditions of Labour	154
34.3	Employment of Persons in the Service of Others	154
34.4	Housing for Labour	154
34.5	Health and Safety	155
34.6	Epidemics	155
34.7	Supply of Water	155
34.8	Alcoholic Liquor or Drugs	155
34.9	Arms and Ammunition	155
34.10	Festivals and Religious Customs	155
34.11	Disorderly Conduct	156
34.12	Compliance by Subcontractors	156
35.2	Records of Safety and Health	156
35.3	Reporting of Accidents	156
36.6	Use of Pakistani Materials and Services	156
41.1	Commencement of Works	156
47.3	Bonus for Early Completion of Works	157
48.2	Taking Over of Sections or Parts	157
51.2	Instructions for Variations	157

TABLE OF CONTENTS

PART II - PARTICULAR CONDITIONS OF CONTRACT

Clause	Title	Page
52.1	Valuation of Variations	157
53.4	Failure to Comply	157
54.3	Customs Clearance	157
54.5	Conditions of Hire of Contractor's Equipment	157
59.4	Payments to Nominated Sub-contractors	157
59.5	Evidence of Payments	158
60.1	Monthly Statements	158
60.2	Monthly Payments	158
60.10	Time for Payment	158
60.11	Secured Advance on Materials	159
60.11	Financial Assistance to Contractor	159
63.1	Default of Contractor	161
65.2	Special Risks	161
67.3	Arbitration	161
68.1	Notice to Contractor	161
68.2	Notice to Procuring Entity and Engineer	162
70.1	Increase or Decrease of Cost	162
73.1	Payment of Income Tax	163
73.2	Customs Duty & Taxes	164
74.1	Integrity Pact	164
75.1	Termination of Contract for Procuring Entity's Convenience	164
76.1	Liability of Contractor	164
77.1	Joint and Several Liability	165
78.1	Details to be Confidential	165

PART II - PARTICULAR CONDITIONS OF CONTRACT
(Mandatory Provisions not to be Amended / Substituted except as instructed by KPPRA)

1.1 Definitions

(a) (i) The Procuring Entity is **Executive Engineer, Charsadda Irrigation Division Charsadda, behalf of Chief Engineer (South) Irrigation Department Phone No. 091-6514641, Email:charsaddairrigation@yahoo.com mentioned in the NIT**

(a) (iv) The Engineer is **Executive Engineer, Charsadda Irrigation Division Charsadda, Phone No. 091-6514641, Email:charsaddairrigation@yahoo.com mentioned in the NIT**

or any other competent person appointed by the Procuring Entity, and notified to the Contractor, to act in replacement of the Engineer. Provided always that except in cases of professional misconduct, the outgoing Engineers is to formulate his certifications/recommendations in relation to all outstanding matters, disputes and claims relating to the execution of the Works during his tenure.

The following paragraph is added:

(a)(vi) “Bidder or Tenderer” means any person or persons, company, corporation, firm or joint venture submitting a Bid or Tender.

(b)(v) The following is added at the end of the paragraph:

The word “Tender” is synonymous with “Bid” and the word “Tender Documents” with “Bidding Documents”.

The following paragraph is added:

(b)(ix) “Program” means the program to be submitted by the Contractor in accordance with Sub-Clause 14.1 and any approved revisions thereto.

(e)(i) The text is deleted and substituted with the following:

“Contract Price” means the sum stated in the Letter of Acceptance as payable to the Contractor for the execution and completion of the Works subject to such additions thereto or deductions therefrom as may be made and remedying of any defects therein in accordance with the provisions of the Contract.

2.1 Engineer's Duties and Authority

With reference to Sub-Clause 2.1(b), the following provisions shall also apply;

The Engineer shall obtain the specific approval of the Procuring Entity before carrying out his duties in accordance with the following Clauses:

- (i) Consenting to the sub-letting of any part of the Works under Sub-Clause 4.1 “Subcontracting.”

- (ii) Certifying additional cost determined under Sub-Clause 12.2 “Not Foreseeable Physical Obstructions or Conditions”.
- (iii) Any action under Clause 10 “Performance Security” and Clauses 21,23,24 & 25 “Insurance” of sorts.
- (iv) Any action under Clause 40 “Suspension”.
- (v) Any action under Clause 44 “Extension of Time for Completion”.
- (vi) Any action under Clause 47 “Liquidated Damages for Delay” or Payment of Bonus for Early Completion of Works (PCC Sub-Clause 47.3).
- (vii) Issuance of “Taking Over Certificate” under Clause 48.
- (viii) Issuing a Variation Order under Clause 51,except:
 - a) in an emergency* situation, as stated here below, or
 - b) if such variation would increase the Contract Price by less than the amount stated in the Appendix-A to Bid.
- (ix) Fixing rates or prices under Clause 52.
- (x) Extra payment as a result of Contractor’s claims under Clause 53.
- (xi) Release of Retention Money to the Contractor under Sub-Clause 60.3 “Payment of Retention Money”.
- (xii) Issuance of “Final Payment Certificate” under Sub-Clause 60.8.
- (xiii) Issuance of “Defect Liability Certificate” under Sub-Clause 62.1.
- ~~(xiv) Any change in the ratios of Contract currency proportions and payments thereof under Clause 72 “Currency and Rate of Exchange”.~~

(Note: NOT APPLICABLE)

(If in the opinion of the Engineer an emergency occurs affecting the safety of life or of the Works or of adjoining property, the Engineer may, without relieving the Contractor of any of his duties and responsibilities under the Contract, instruct the Contractor to execute all such work or to do all such things as may, in the opinion of the Engineer, be necessary to abate or reduce the risk. The Contractor shall forthwith comply with any such instruction of the Engineer. The Engineer may determine an addition to the Contract Price, in respect of such instruction, in accordance with Clause 52 and shall notify the Contractor accordingly, with a copy to the Procuring Entity.) However, responsibility of restoring damages to ongoing work will be within the contract price and liability of the contractor

2.2 Engineer's Representative

The following paragraph is added:

The Procuring Entity shall ensure that the Engineer's Representative is a Sub Divisional Officer or superior, posted by the competent authority (GOP).

The following Sub-Clauses 2.7 and 2.8 are added:

2.7 Engineer Not Liable

Approval, reviews and inspection by the Engineer of any part of the Works does not relieve the Contractor from his sole responsibility and liability for the supply of materials, plant and equipment for construction of the Works and their parts in accordance with the Contract and neither the Engineer's authority to act nor any decision made by him in good faith as provided for under the Contract whether to exercise or not to exercise such authority shall give rise to any duty or responsibility of the Engineer to the Contractor, any Subcontractor, any of their representatives or employees or any other person performing any portion of the Works.

2.8 Replacement of the Engineer

“If the Procuring Entity intends to replace the Engineer, the Procuring Entity shall, not less than 14 days before the intended date of replacement, give notice to the Contractor, of the name, address and relevant experience of the intended replacement Engineer. The Procuring Entity shall not replace the Engineer with a person against whom the Contractor raises reasonable objection by notice to the Procuring Entity, with supporting particulars.”

5.1 Language(s) and Law

- (a) The Contract Documents, shall be drawn up in the English language.
- (b) The Contract shall be subject to the Laws of Islamic Republic of Pakistan.

5.2 Priority of Contract Documents

The documents listed at (1) to (6) of the Sub-Clause are deleted and substituted with the following:

- (1) The Contract Agreement (if completed);
- (2) The Letter of Acceptance;
- (3) The completed Form of Bid;
- (4) Special Stipulations (Appendix-A to Bid);
- (5) The Particular Conditions of Contract – Part II;
- (6) The General Conditions – Part I;
- (7) The priced Bill of Quantities (Appendix-D to Bid);
- (8) The completed Appendices to Bid (B, C, E to L);
- (9) The Drawings;

- (10) The Specifications; and
(11) _____ (any other).

In case of discrepancies between drawings, those of larger scale shall govern unless they are superseded by a drawing of later date regardless of scale. All Drawings and Specifications shall be interpreted in conformity with the Contract and these Conditions. Addendum, if any, shall be deemed to have been incorporated at the appropriate places in the documents forming the Contract.

The following Sub-Clauses 6.6 and 6.7 are added:

6.6 Shop Drawings (As per requirement of Engineer incharge, if required)

The Contractor shall submit to the Engineer for review 3 copies of all shop and erection drawings applicable to this Contract as per provision of relevant Sub-Clause of the Contract, if required by Engineer:

Review and approval by the Engineer shall not be construed as a complete check but will indicate only that the general method of construction and detailing is satisfactory and that the Engineer's review or approval shall not relieve the Contractor of any of his responsibilities under the Contract.

6.7 As-Built Drawings (As per requirement of Engineer incharge, if required)

If required by the Engineer, at the completion of the Works under the Contract, the Contractor shall furnish to the Engineer 6 copies and one reproducible of all drawings amended to conform with the Works as built. The price of such Drawings shall be deemed to be included in the Contract Price.

10.1 Performance Security

The Contractor shall provide Performance Security to the Procuring Entity in the prescribed form. The said Security shall be furnished or caused to be furnished by the Contractor within 28 days after the receipt of the Letter of Acceptance. The Performance Security shall be of an amount equal to 10% of the Contract Price stated in the Letter of Acceptance. Such Security shall, at the option of the bidder, be in the form of either (a) bank guarantee from any Scheduled Bank in Pakistan or (b) bank guarantee from a bank located outside Pakistan duly counter-guaranteed by a Scheduled Bank in Pakistan [deleted]⁶.

The cost of complying with requirements of this Sub-Clause shall be borne by the Contractor.

The following Sub-Clause 10.4 is added:

⁶ Words "(c) an insurance company having at least AA rating from PACRA/JCR" deleted by KPPRA Notification No. KPPRA/M&E/Estt:/1-4/2016 dated May 24, 2016.

10.4 Performance Security Binding on Variations and Changes

The Performance Security shall be binding irrespective of changes in the quantities or variations in the Works or extensions in Time for Completion of the Works which are granted or agreed upon under the provisions of the Contract.

14.1 Program to be Submitted

(If required) The program shall be submitted within 28 days from the date of receipt of Letter of Acceptance, which shall be in the form of:

a Bar Chart identifying the critical activities.

14.3 Cash Flow Estimate to be Submitted

The detailed Cash Flow Estimate shall be submitted within 21 days from the date of receipt of Letter of Acceptance (Payment shall be subject to availability of fund, work done, other works, importance of works as deemed appropriate according to situation by the Procuring Entity)

The following Sub-Clause 14.5 is added:

14.5 Detailed Program and Monthly Progress Report (if required by the Engineer)

- a) For purposes of Sub-Clause 14.1, the Contractor shall submit to the Engineer detailed program for the following:
- (1) Execution of Works;
 - (2) Labour Employment;
 - (3) Local Material Procurement;
 - (4) Material Imports, if any; and
 - (5) Other details as required by the Engineer.
- (b) During the period of the Contract, the Contractor shall submit to the Engineer not later than the 8th day of the following month, 5 copies each of Monthly Progress Reports covering:
- (1) A Construction Schedule indicating the monthly progress in percentage;
 - (2) Description of all work carried out since the last report;
 - (3) Description of the work planned for the next 56 days sufficiently detailed to enable the Engineer to determine his program of inspection and testing;
 - (4) Monthly summary of daily job record;
 - (5) Photographs to illustrate progress ;and
 - (6) Information about problems and difficulties encountered, if any, and proposals to overcome the same.
- (c) During the period of the Contract, the Contractor shall keep a daily record of the work progress, which shall be made available to the Engineer as and when requested. The

daily record shall include particulars of weather conditions, number of men working, deliveries of materials, quantity, location and assignment of Contractor's equipment.

The following Sub-Clauses 15.2 and 15.3 are added:

15.2 Language Ability of Contractor's Representative

The Contractor's authorized representative shall be fluent in the English/Urdu/Pashto language.

15.3 Contractor's Representative

The Contractor's representative will be a professional engineer working at Site registered with the Pakistan Engineering Council.

The Contractor's authorized representative at Site shall be authorized to exercise adequate administrative and financial powers on behalf of the Contractor so as to achieve completion of the Works as per the Contract.

The following Sub-Clauses 16.3 and 16.4 are added:

16.3 Language Ability of Superintending Staff of Contractor (N/A)

A reasonable proportion of the Contractor's superintending staff shall have a working knowledge of the English/Urdu/Pashto language.

16.4 Employment of Local Personnel

The Contractor is encouraged, to the extent practicable and reasonable, to employ staff and labour from sources within Khyber Pakhtunkhwa Province.

The following Sub-Clauses 19.3 and 19.4 are added:

19.3 Safety Precautions

In order to provide for the safety, health and welfare of persons, and for prevention of damage of any kind, all operations for the purposes of or in connection with the Contract shall be carried out in compliance with the Safety Requirements of the Government of Pakistan and KPK with such modifications thereto as the Engineer may authorize or direct and the Contractor shall take or cause to be taken such further measures and comply with such further requirements as the Engineer may determine to be reasonably necessary for such purpose.

The Contractor shall make, maintain and submit reports to the Engineer concerning safety, health and welfare of persons and damage to property, as the Engineer may from time to time prescribe.

The contractor shall provide all the safety gear to its employees and also put safety / diversion signs with messages for ease of public traffic movement. Whiles incorporating cost in the bids, such cost provisions shall also be made and will not be adjusted separately.

19.4 Lighting Work at Night

In the event of work being carried out at night, the Contractor shall at his own cost, provide and maintain such good and sufficient light as will enable the work to proceed satisfactorily and without danger. The approaches to the Site and the Works where the night-work is being carried out shall be sufficiently lighted. All arrangement adopted for such lighting shall be to the satisfaction of the Engineer's Representative.

20.4 Procuring Entity's Risks

The Procuring Entity's risks are:

- (a) insofar as they directly affect the execution of the Works in Khyber Pakhtunkhwa Province
 - (i) war and hostilities (whether war be declared or not), invasion, act of foreign enemies,
 - (ii) rebellion, revolution, insurrection, or military or usurped power, or civil war,
 - (iii) ionizing radiations, or contamination by radioactivity from any nuclear fuel, or from any nuclear waste from the combustion of nuclear fuel, radioactive toxic explosive or other hazardous properties of any explosive nuclear assembly or nuclear component thereof,
 - (iv) pressure waves caused by aircraft or other aerial devices travelling at sonic or supersonic speeds,
 - (v) riot, commotion or disorder, unless solely restricted to the employees of the Contractor or of his Subcontractors and arising from the conduct of the Works;
- (b) loss or damage due to the use or occupation by the Procuring Entity of any Section or part of the Permanent Works, except as may be provided for in the Contract;
- (c) any operation of the forces of nature (insofar as it occurs on the Site) which an experienced contractor:
 - (i) could not have reasonably foreseen, or
 - (ii) could reasonably have foreseen, but against which he could not reasonably have taken at least one of the following measures:
 - (a) prevent loss or damage to physical property from occurring by taking appropriate measures, or
 - (b) insure against.

21.1 Insurance of Works and Contractor's Equipment

(Procuring Entity may vary this Sub-clause 1.1 (b))

21.4 Exclusions

The text is deleted and substituted with the following:

There shall be no obligation for the insurances in Sub-Clause 21.1 to include loss or damage caused by the risks listed under Sub-Clause 20.4 para (a) (i) to (iv).

The following Sub-Clause 25.5 is added:

25.5 Insurance Company

The Contractor shall be obliged to place all insurances relating to the Contract (including, but not limited to, the insurances referred to in Clauses 21, 23 and 24) with either National Insurance Company of Pakistan or any other insurance company operating in Pakistan and acceptable to the Procuring Entity.

Costs of such insurances shall be borne by the Contractor.

The following Sub-Clause 31.3 is added:

31.3 Co-operation with other Contractors

During the execution of the Works, the Contractor shall co-operate fully with other contractors working for the Procuring Entity at and in the vicinity of the Site and also shall provide adequate precautionary facilities not to make himself a nuisance to local residents and other contractors.

The following Sub-Clauses 34.2 to 34.12 are added:

34.2 Rates of Wages and Conditions of Labour

The Contractor shall pay rates of wages and observe conditions of labour not less favourable than those established for the trade or industry where the work is carried out. In the absence of any rates of wages or conditions of labour so established, the Contractor shall pay rates of wages and observe conditions of labour which are not less favourable than the general level of wages and conditions observed by other Procuring Entities whose general circumstances in the trade or in industry in which the Contractor is engaged are similar.

34.3 Employment of Persons in the Service of Others

The Contractor shall not recruit his staff and labour from amongst the persons in the services of the Procuring Entity or the Engineer; except with the prior written consent of the Procuring Entity or the Engineer, as the case may be.

34.4 Housing for Labour

Save insofar as the Contract otherwise provides, the Contractor shall provide and maintain such housing accommodation and amenities as he may consider necessary for all his supervisory staff and labour, employed for the purposes of or in connection with the Contract including all fencing, electricity supply, sanitation, cookhouses, fire prevention, water supply and other requirements in connection with such housing accommodation or amenities. On completion of the Contract the temporary camps or housing provided by the Contractor shall be removed and the Site reinstated to its original condition, all to the approval of the Engineer.

34.5 Health and Safety

Due precautions shall be taken by the Contractor, and at his own cost, to ensure the safety of his staff and labour at all times throughout the period of the Contract. The Contractor shall further ensure that suitable arrangements are made for the prevention of epidemics and for all necessary welfare and hygiene requirements.

34.6 Epidemics

In the event of any outbreak of illness of an epidemic nature, the Contractor shall comply with and carry out such regulations, orders and requirements as may be made by the Government, or the local medical or sanitary authorities, for purpose of dealing with and overcoming the same.

34.7 Supply of Water

The Contractor shall, so far as is reasonably practicable, having regard to local conditions, provide on the Site, to the satisfaction of the Engineer or his representative, adequate supply of drinking and other water for the use of his staff and labour.

34.8 Alcoholic Liquor or Drugs

The Contractor shall not, otherwise than in accordance with the Statutes, Ordinances and Government Regulations or Orders for the time being in force, import, sell, give, barter or otherwise dispose of any alcoholic liquor or drugs, or permit or suffer any such importation, sale, gift, barter or disposal by his Subcontractors, agents, staff or labour.

34.9 Arms and Ammunition

The Contractor shall not give, or otherwise dispose of to any person or persons, any arms or ammunition of any kind or permit or suffer the same as aforesaid.

34.10 Festivals and Religious Customs

The Contractor shall in all dealings with his staff and labour have due regard to all recognized festivals, days of rest and religious and other customs.

34.11 Disorderly Conduct

The Contractor shall at all times take all reasonable precautions to prevent any unlawful, riotous or disorderly conduct by or amongst staff and labour and for the preservation of peace and protection of persons and property in the neighborhood of the Works against the same.

34.12 Compliance by Subcontractors

The Contractor shall be responsible for compliance by his Subcontractors of the provisions of this Clause.

The following Sub-Clauses 35.2 and 35.3 are added:

35.2 Records of Safety and Health

The Contractor shall maintain such records and make such reports concerning safety, health and welfare of persons and damage to property as the Engineer may from time to time prescribe.

35.3 Reporting of Accidents

The Contractor shall report to the Engineer details of any accident as soon as possible after its occurrence. In the case of any fatality or serious accident, the Contractor shall, in addition, notify the Engineer immediately by the quickest available means.

The following Sub-Clause 36.6 is added:

36.6 Use of Pakistani Materials and Services

The Contractor shall , so far as may be consistent with the Contract, make the maximum use of materials, supplies, plant and equipment indigenous to or produced or fabricated in Pakistan and services, available in Pakistan preferably in Khyber Pakhtunkhwa Province provided such materials, supplies, plant, equipment and services shall be of required standard.

41.1 Commencement of Works

The text is deleted and substituted with the following:

The Contractor shall commence the Works on Site within the period named in Appendix-A to Bid from the date of receipt by him from the Engineer of a written Notice to Commence. Thereafter, the Contractor shall proceed with the Works with due expedition and without delay.

The following Sub-Clause 47.3 is added:

47.3 Bonus for Early Completion of Works (Not Applicable)

The Contractor shall in case of earlier completion for either whole or part(s) of the Works pursuant to Sub-Clauses 48.1 and 48.2(a) respectively of the General Conditions of Contract, be paid bonus up-to a limit and at a rate equivalent to 50% of the relevant limit and rate of liquidated damages prescribed in Appendix-A to Bid “Special Stipulations”.

48.2 Taking Over of Sections or Parts

For the purposes of para (a) of this Sub-Clause, separate Times for Completion shall be provided in the Appendix-A to Bid “Special Stipulations”.

51.2 Instructions for Variations

At the end of the first sentence, after the word “Engineer”, the words “in writing” are added.

52.1 Valuation of Variations

In the tenth line, after the words “Engineer shall” the following is added: within a period not exceeding one-eighth of the completion time subject to a minimum of 28 days from the date of disagreement whichever is later.

53.4 Failure to Comply

This Sub-Clause is deleted in its entirety.

54.3 Customs Clearance

(Procuring Entity may vary this Sub-Clause)

54.5 Conditions of Hire of Contractor’s Equipment

The following paragraph is added:

The Contractor shall, upon request by the Engineer at any time in relation to any item of hired Contractor’s Equipment, forthwith notify the Engineer in writing the name and address of the Owner of the equipment and shall certify that the agreement for the hire thereof contains a provision in accordance with the requirements set forth above.

The following Sub-Clauses 59.4 & 59.5 are added:

59.4 Payments to Nominated Subcontractors

The Contractor shall pay to the nominated Subcontractor the amounts which the Engineer certifies to be due in accordance with the subcontract. These amounts plus other charges shall be included in the Contract Price in accordance with Clause 58 [Provisional Sums], except as stated in Sub-Clause 59.5 [Certification of Payments].

59.5 Certification of Payments & Nominated Subcontractors

Before issuing a Payment Certificate which includes an amount payable to a nominated Subcontractor, the Engineer may request the Contractor to supply reasonable evidence that the nominated Subcontractor has received all amounts due in accordance with previous Payment Certificates, less applicable deductions for retention or otherwise. Unless the Contractor:

- a) submits reasonable evidence to the Engineer, or
- b) i) satisfies the Engineer in writing that the Contractor is reasonably entitled to withhold or refuse to pay these amounts, and
ii) submits to the Engineer reasonable evidence that the nominated Subcontractor has been notified of the Contractor's entitlement,

then the Procuring Entity may (at his sole discretion) pay direct to the nominated Subcontractor, part or all of such amounts previously certified (less applicable deductions) as are due to the nominated Subcontractor and for which the Contractor has failed to submit the evidence described in sub-paragraphs (a) or (b) above. The Contractor shall then repay, to the Procuring Entity, the amount which the nominated Subcontractor was directly paid by the Procuring Entity.

60.1 Monthly Statements

In the first line after the word "shall", the following is added:

"on the basis of the joint measurement of work done under Clause 56.1,"

In Para (c) the words "the Appendix to Tender" are deleted and substituted with the words "Sub-Clause 60.11 (a)(6) hereof". (in case Clause 60.11 is applicable)

60.2 Monthly Payments

In the first line, "28" is substituted by "14".

60.10 Time for Payment

The text is deleted and substituted with the following:

The amount due to the Contractor under any Interim Payment Certificate issued by the Engineer pursuant to this Clause, or to any other terms of the Contract, shall, subject to Clause 47, be paid by the Procuring Entity to the Contractor within 30 days after such Interim Payment Certificate has been jointly verified by Procuring Entity and Contractor (Subject to availability of fund, importance in relation to other works, decision of the Procuring Entity) or, in the case of the Final Certificate referred to in Sub Clause 60.8, within 60 days (Subject to availability of fund, importance in relation to other works, decision of the Procuring Entity) after such Final Payment Certificate has been jointly verified by Procuring Entity and Contractor.

The following Sub-Clause 60.11 is added:

60.11 Secured Advance on Materials

- a) The Contractor shall be entitled to receive from the Procuring Entity Secured Advance against an indemnity bond acceptable to the Procuring Entity of such sum as the Engineer may consider proper in respect of non-perishable materials brought at the Site but not yet incorporated in the Permanent Works provided that:
- (1) The materials are in accordance with the Specifications for the Permanent Works;
 - (2) Such materials have been delivered to the Site and are properly stored and protected against loss or damage or deterioration to the satisfaction of the Engineer but at the risk and cost of the Contractor;
 - (3) The Contractor's records of the requirements, orders, receipts and use of materials are kept in a form approved by the Engineer, and such records shall be available for inspection by the Engineer;
 - (4) The Contractor shall submit with his monthly statement the estimated value of the materials on Site together with such documents as may be required by the Engineer for the purpose of valuation of materials and providing evidence of ownership and payment therefor;
 - (5) Ownership of such materials shall be deemed to vest in the Procuring Entity and these materials shall not be removed from the Site or otherwise disposed of without written permission of the Procuring Entity; and
 - (6) The sum payable for such materials on Site shall not exceed 75 % of the (i) landed cost of imported materials, or (ii) ex-factory / ex-warehouse price of locally manufactured or produced materials, or (iii) market price of other materials.
- (b) The recovery of Secured Advance paid to the Contractor under the above provisions shall be effected from the monthly payments on actual consumption basis or in installments as deemed appropriate by the Procuring Entity.

60.11 Financial Assistance to Contractor

Financial assistance shall be made available to the Contractor by the Procuring Entity by adopting any one of the following three Alternatives:

(Appropriate alternative only to be retained)

Alternative One: Mobilization Advance (Subject to Availability/release of Funds)

- (a) An interest-free Mobilization Advance 10-15 % of the Contract Price stated in the Letter of Acceptance shall be paid by the Procuring Entity to the Contractor in two equal parts
- (b) upon submission by the Contractor of a Mobilization Advance Guarantee/ for the full amount of the Advance in the specified form from a Scheduled Bank in Pakistan :
 - (1) First part within 14 days after signing of the Contract Agreement or date of receipt of Engineer's Notice to Commence, whichever is earlier; and
 - (2) Second part within 42 days from the date of payment of the first part, subject to the satisfaction of the Engineer as to the state of mobilization of the Contractor.
- (b) This Advance shall be recovered in equal installments; first installment at the expiry of third month after the date of payment of first part of Advance and the last installment two months before the date of completion of the Works as per Clause 43 hereof.

63.1 Default of Contractor

The following para is added at the end of the Sub-Clause:

Provided further that in addition to the action taken by the Procuring Entity against the Contractor under this Clause, the Procuring Entity may also refer the case of default of the Contractor to Pakistan Engineering Council for punitive action under the Construction and Operation of Engineering Works Bye-Laws 1987, as amended from time to time as well as under the prevailing rules of KPPRA.

65.2 Special Risks

The text is deleted and substituted with the following:

The Special Risks are the risks defined under Sub-Clause 20.4 sub paragraphs (a) (i) to (a) (v).

67.3 Arbitration

In the sixth to eight lines, the words "shall be finally settled appointed under such Rules" are deleted and substituted with the following:

shall be finally settled under the provisions of the Arbitration Act, 1940 as amended or any statutory modification or re-enactment thereof for the time being in force.

The following paragraph is added:

The place of arbitration shall be Charsadda, Pakistan.

If in conflict with KPPRA Act & Rules then KPPRA Act & Rules shall be followed.

68.1 Notice to Contractor

The following paragraph is added:

For the purposes of this Sub-Clause, the Contractor shall, immediately after receipt of Letter of Acceptance, intimate in writing to the Procuring Entity and the Engineer by registered post, the address of his principal place of business or any change in such address during the period of the Contract.

68.2 Notice to Procuring Entity and Engineer

For the purposes of this Sub-Clause, the respective address are:

a) The Procuring Entity :
Executive Engineer, Charsadda Irrigation Division Charsadda, behalf of Chief Engineer (South) Irrigation Department Phone No. 091-6514641, Email:charsaddairrigation@yahoo.com mentioned in the NIT

b) The Engineer: **Executive Engineer, Charsadda Irrigation Division Ccarsadda, Phone No. 091-6514641, Email:charsaddairrigation@yahoo.com mentioned in the NIT**

70.1 Increase or Decrease of Cost

Sub-Clause 70.1 is deleted in its entirety, and substituted with the following:

(NOT APPLICABLE)

The following Sub-Clauses 73.1, 73.2, 74.1, 75.1, 76.1, 77.1 and 78.1 are added:

73.1 Payment of Income Tax

The Contractor, Subcontractors and their employees shall be responsible for payment

of all their income tax, super tax and other taxes on income arising out of the Contract and the rates and prices stated in the Contract shall be deemed to cover all such taxes.

73.2 Customs Duty & Taxes

These shall be the responsibility of the contractor as per prevailing rules & law.

74.1 Integrity Pact

If the Contractor or any of his Subcontractors, agents or servants is found to have violated or involved in violation of the Integrity Pact signed by the Contractor as Appendix-L to his Bid, then the Procuring Entity shall be entitled to:

- (a) recover from the Contractor an amount equivalent to ten times the sum of any commission, gratification, bribe, finder's fee or kickback given by the Contractor or any of his Subcontractors, agents or servants;
- (b) terminate the Contract; and
- (c) Recover from the Contractor any loss or damage to the Procuring Entity as a result of such termination or of any other corrupt business practices of the Contractor or any of his Subcontractors, agents or servants.

The termination under Sub-Para (b) of this Sub-Clause shall proceed in the manner prescribed under Sub-Clauses 63.1 to 63.4 and the payment under Sub-Clause 63.3 shall be made after having deducted the amounts due to the Procuring Entity under Sub-Para (a) and (c) of this Sub-Clause.

75.1 Termination of Contract for Procuring Entity's Convenience

The Procuring Entity shall be entitled to terminate the Contract at any time for the Procuring Entity's convenience after giving 56 days prior notice to the Contractor, with a copy to the Engineer. In the event of such termination, the Contractor :

- (a) shall proceed as provided in Sub-Clause 65.7 hereof; and
- (b) shall be paid by the Procuring Entity as provided in Sub-Clause 65.8 hereof.

76.1 Liability of Contractor

The Contractor or his Subcontractors or assigns shall follow strictly, all relevant

labour laws including the Workmen's Compensation Act and the Procuring Entity shall be fully indemnified for all claims, damages etc. arising out of any dispute between the Contractor, his Subcontractors or assigns and the labour employed by them.

77.1 Joint and Several Liability

If the Contractor is a joint venture of two or more persons, all such persons shall be jointly and severally bound to the Procuring Entity for the fulfillment of the terms of the Contract and shall designate one of such persons to act as leader with authority to bind the joint venture. The composition or the constitution of the joint venture shall not be altered without the prior consent of the Procuring Entity.

78.1 Details to be Confidential

The Contractor shall treat the details of the Contract as private and confidential, save in so far as may be necessary for the purposes thereof, and shall not publish or disclose the same or any particulars thereof in any trade or technical paper or elsewhere without the prior consent in writing of the Procuring Entity or the Engineer. If any dispute arises as to the necessity of any publication or disclosure for the purpose of the Contract, the same shall be referred to the decision of the Engineer whose award shall be final.

PART II –PARTICULAR CONDITIONS OF CONTRACT

Index	Clause
Alcoholic Liquor or Drugs	34.8
Arbitration	67.3
Arms and Ammunition	34.9
As-Built Drawings	6.7
Bonus for Early Completion of Works	47.3
Cash Flow Estimate to be Submitted	14.3
Commencement of Works	41.1
Compliance by Sub-Contractors	34.12
Conditions of Hire of Contractor's Equipment	54.5
Contractor's Representative	15.3
Co-operation with Other Contractors	31.3
Customs Clearance	54.3
Customs Duty and Taxes	73.2
Default of Contractor	63.1
Definitions	1.1
Detailed Program and Monthly Progress Report	14.5
Details to be Confidential	78.1
Disorderly Conduct	34.11
Procuring Entity's Risks	20.4
Local Personnel	16.4
Employment of Persons in the Service of Others	34.3
Engineer Not Liable	2.7
Employment of Engineer's Duties and Authority	2.1
Engineer's Representative	2.2
Epidemics	34.6
Exclusions	21.4
Failure to Comply	53.4
Festivals and Religious Customs	34.10
Financial Assistance to Contractor	60.11
Health and Safety	34.5
Housing for Labour	34.4
Increase or Decrease of Cost	70.1
Instructions for Variations	51.2
Insurance of Works and Contractor's Equipment	21.1
Insurance Company	25.5
Integrity Pact	74.1
Joint and Several Liability	77.1
Language Ability of Contractor's Representative	15.2
Language Ability of Superintending Staff of Contractor	16.3
Language(s) and Law	5.1
Liability of Contractor	76.1

Index	Clause
Lighting Work at Night	19.4
Monthly Payments	60.2
Monthly Statements	60.1
Notice to Contractor	68.1
Notice to Procuring Entity and Engineer	68.2
Payment of Income Tax	73.1
Payments of Nominated Subcontractors	59.4
Performance Security	10.1
Performance Security Binding on Variation and Changes	10.4
Priority of Contract Documents	5.2
Program to be Submitted	14.1
Rates of Wages and Conditions of Labour	34.2
Records of Safety and Health	35.2
Replacement of the Engineer	2.8
Reporting of Accidents	35.3
Safety Precautions	19.3
Secured Advance on Materials	60.11
Shop Drawings	6.6
Special Risks	65.2
Supply of Water	34.7
Taking Over of Sections or Parts	48.2
Termination of Contract for Procuring Entity's Convenience	75.1
Time for Payment	60.10
Use of Pakistani Materials and Services	36.6
Valuation of Variations	52.1

SPECIFICATIONS- SPECIAL PROVISIONS

Essential Material specification as per document at the following link are required:
<https://www.cwd.gkp.pk/images/CSR/Material-Specifications-MRS-KPK-2022.pdf>

SPECIFICATIONS- TECHNICAL PROVISIONS

Essential technical specification as per document at the following link are required:
<https://www.cwd.gkp.pk/images/CSR/Technical-Specification-MRS-KPK-2022.pdf>

DRAWING

As per PC-I/T.S and subsequent sanctions as per site requirement

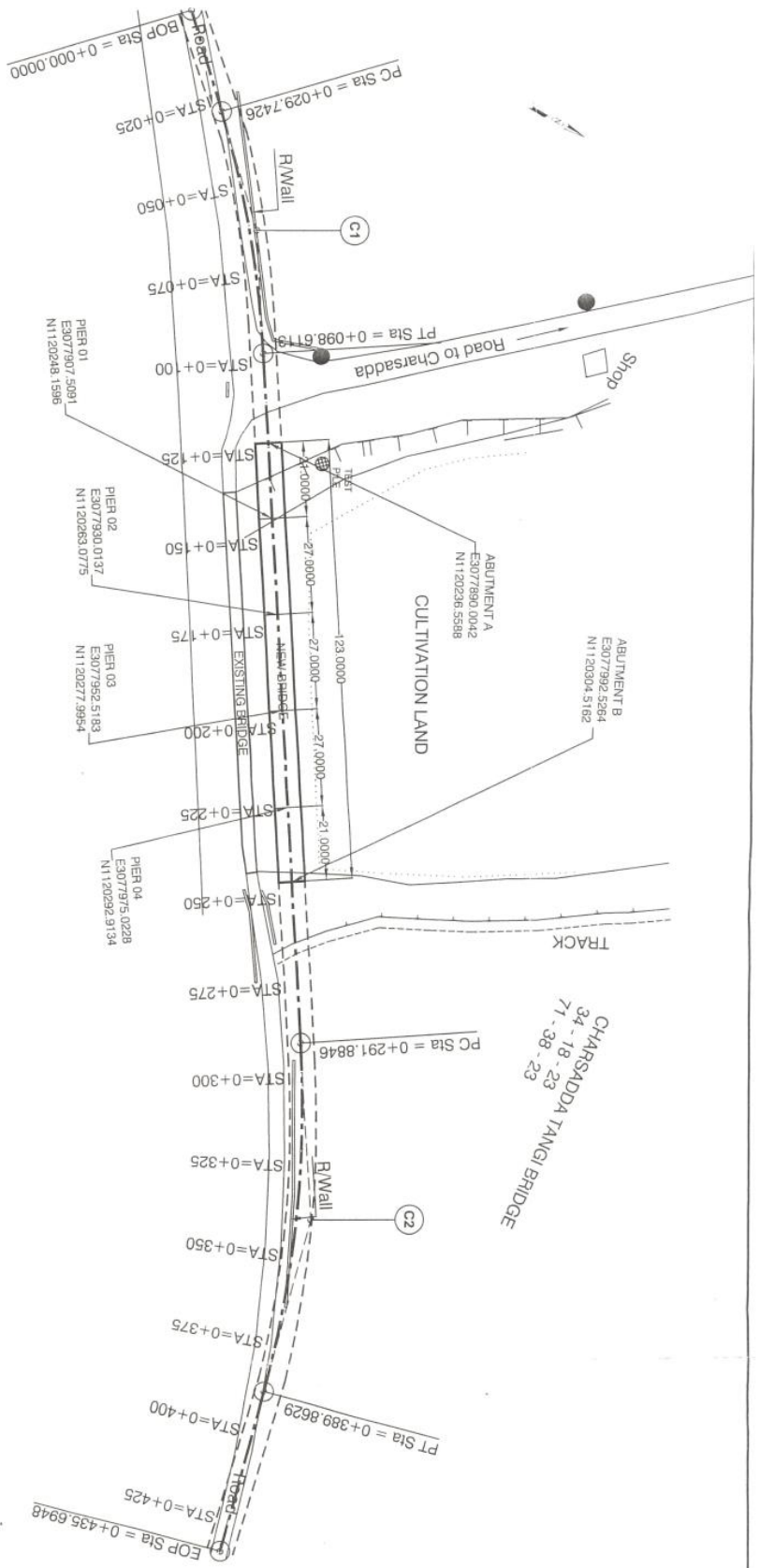

CHARZADDA TANGI BRIDGE
 34 - 18 - 23
 71 - 38 - 23

HORIZONTAL ALIGNMENT DATA

S.No	STATION	PC	PI	PT	NORTHING			EASTING			DEFLECTION ANGLE	Distance	CURVE ELEMENTS				
					NORTHING	EASTING	ELEV	NORTHING	EASTING	ELEV			T	R	L	E	
BOP	0+000.000																
1	0+064.329	0+029.743	0+064.329	0+098.611	1120156.72	3077796.061	351.071	NE43.1826	64.329	34.586	300	68.869	1.987				
2	0+341.314	0+291.885	0+341.314	0+389.863	1120203.532	3077840.185	352.000	NE56.2737	277.289	49.429	300	97.978	4.045				
EOP	0+435.695				1120381.116	3078163.395	351.541	NE75.1022	95.261								

DATOONO BRIDGE TRIVERS DATA

S.NO	EAST	NORTH	ELEV	DESC
1	3077873.811	1120240.642	351.071	T1
2	3077887.605	1120230.919	352.000	T2
3	3078002.436	1120302.568	352.134	T3
4	3078014.243	1120313.070	352.273	T4
5	3077866.214	1120224.548	351.541	T5

CONSTRUCTION DRAWINGS

SCALES:
 1M = 60MM HORIZ
 1M = 60MM VERT

GOVT OF KHYBER PAKHTUNKHWA
 IRRIGATION DEPARTMENT CHARZADDA



DMC

Development Management Consultants

Consulting Engineers, Economists, Architects, Planners & Management Scientists

Office No. 24, Block-8, 3rd Floor, Cantonment Phase-5, Saddar, Rawalpindi

Phone: 031-3578780, 3578979 Fax: (031) 3578981

Email: dmc@dmcpk.com

Unit: KPK, Pakistan

JAS-AWAZ



Date of Revision	Designed By	Checked By	Surveyed By	Drawn By
	M. Siddique	Shahzad Ahmad	Zain ul Waqab	Nabi Amin

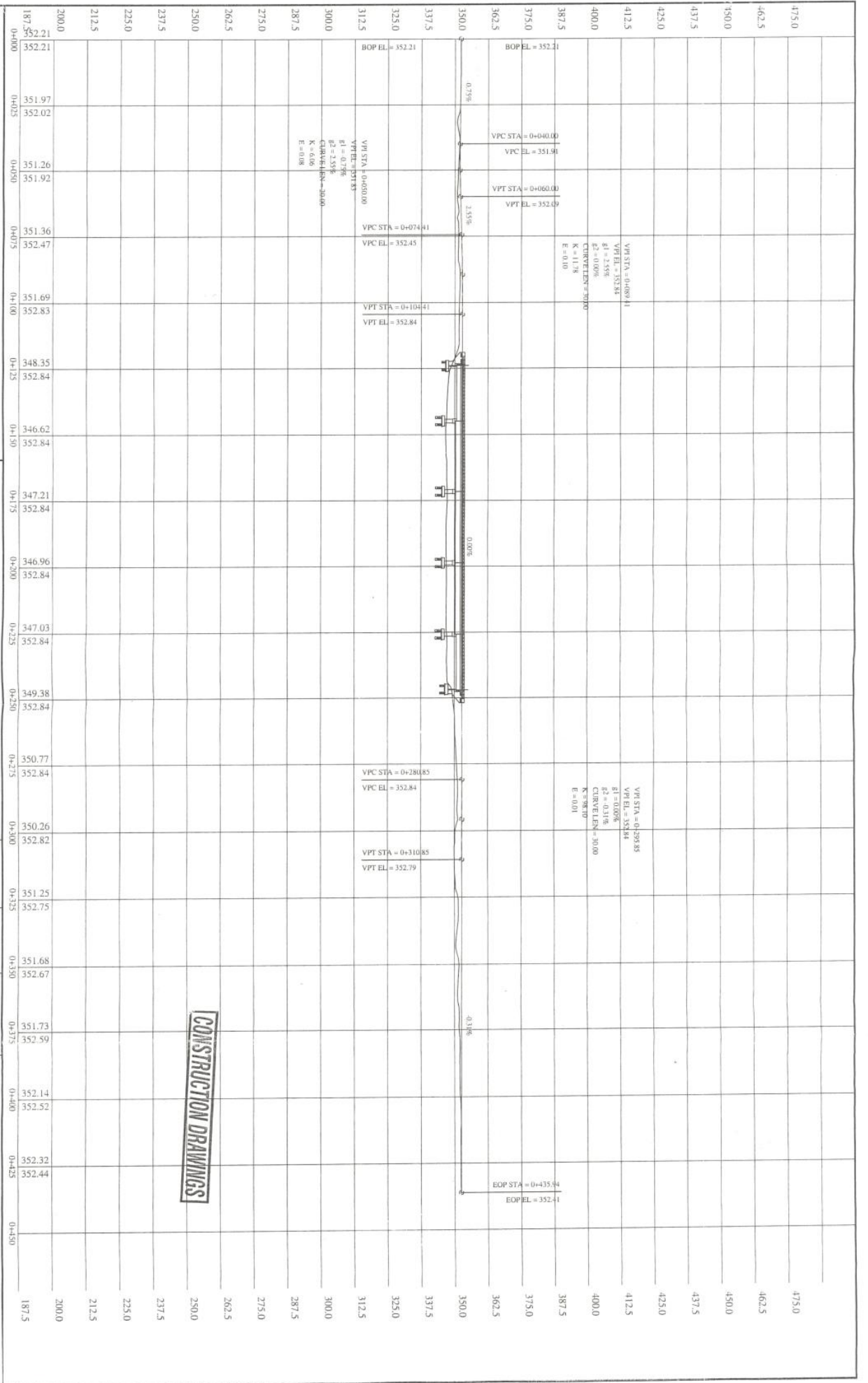

GOVT OF KHYBER PAKHTUNKHWA
IRRIGATION DEPARTMENT CHARSAADA

DMC
Development Management Consultants
Consulting Engineers, Economists, Architects, Planners & Management Specialists
Office No. 24 Block-8, 2nd Floor, "Cafeteria Plaza" Saidu Road Peshawar
Gandapur, Chakdara
Phone: 091 5278001, 5278002, 5278079 Fax: (091 5278081)
JAS-ANZ

Date of Revision	Designed By	M. Siddique
0+325	Checked By	Shahzad Ahmad
0+350	Surveyed By	Zain ul Waqib
0+375	Drawn By	Nabi Amin

CONSTRUCTION DRAWINGS

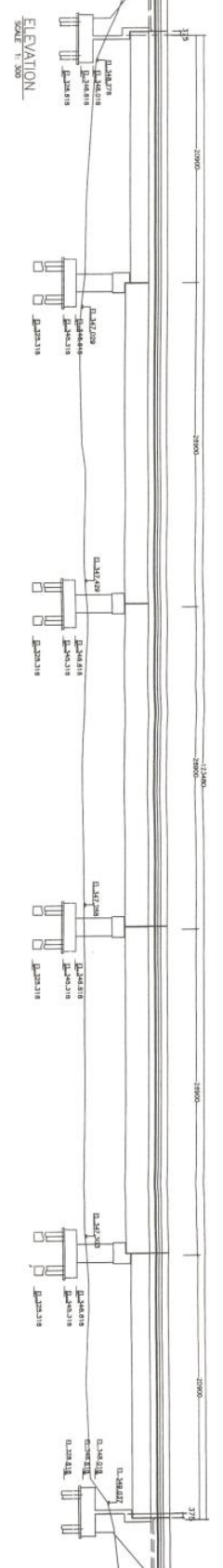

ELEVATION
SCALE 1: 300

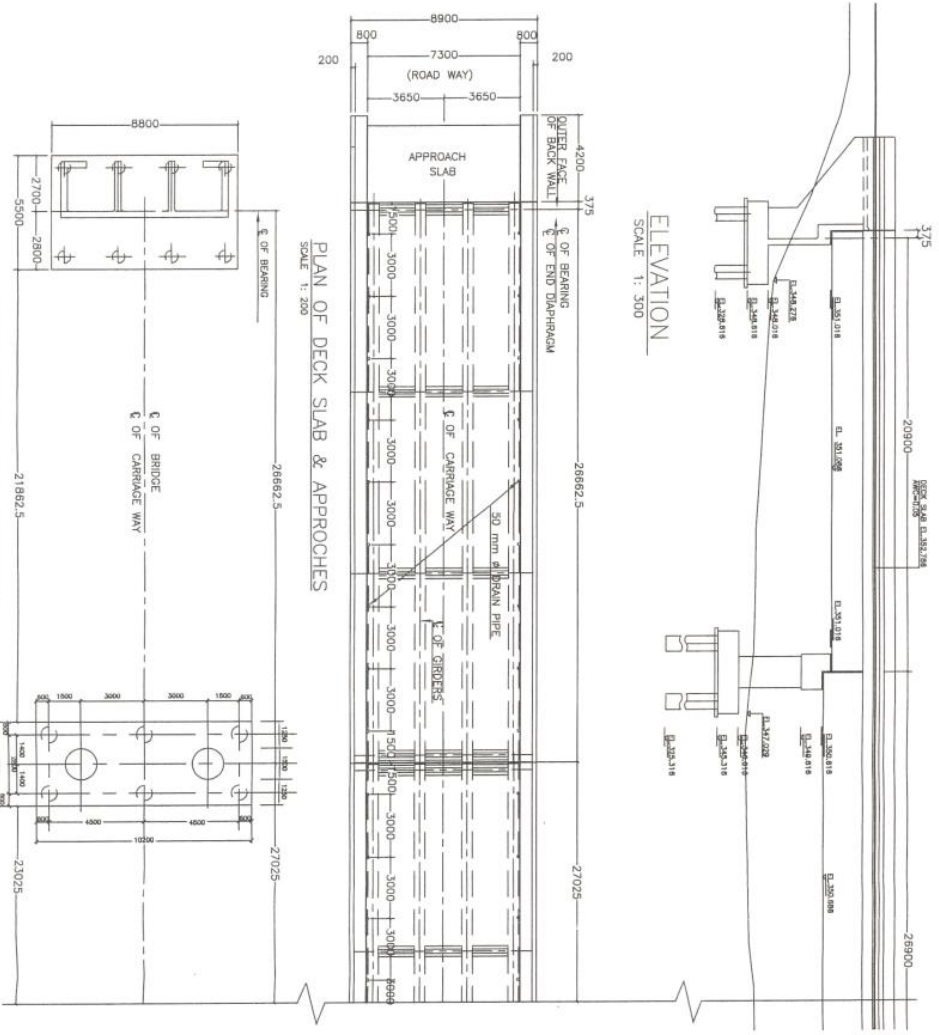

PLAN SHOWING SUB-STRUCTURE
SCALE 1: 200

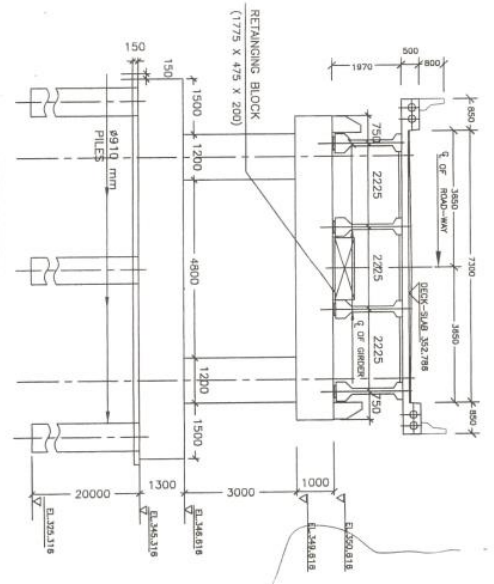
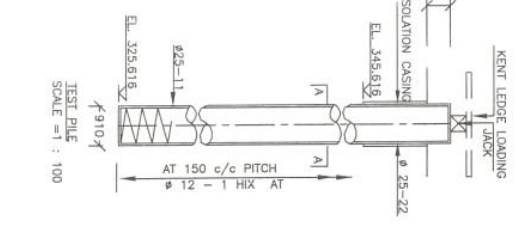

CONSTRUCTION DRAWINGS

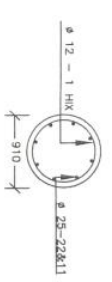

REV	DATE	REVISIONS	DRAWN	DESIGNED	CHKD/VER	APPROVED	SCALE
O1			NABI AMIN	M. SIDDIQUE			
O2				SHEHZAD AHMAD			
O3							1 : 100

GOVT OF KHYBER PAKHTUNKHWA
IRRIGATION DEPARTMENT CHARASADA

D M C
Development Management Consultants
Consulting Engineers, Economists, Planners & Management Specialists
Office No. 4, 2nd Floor, Cement Plaza, Saddle Road, Peshawar, PAKISTAN
Phone: (99) 911378888, (99) 911378888, (99) 911378888, (99) 911378888, (99) 911378888

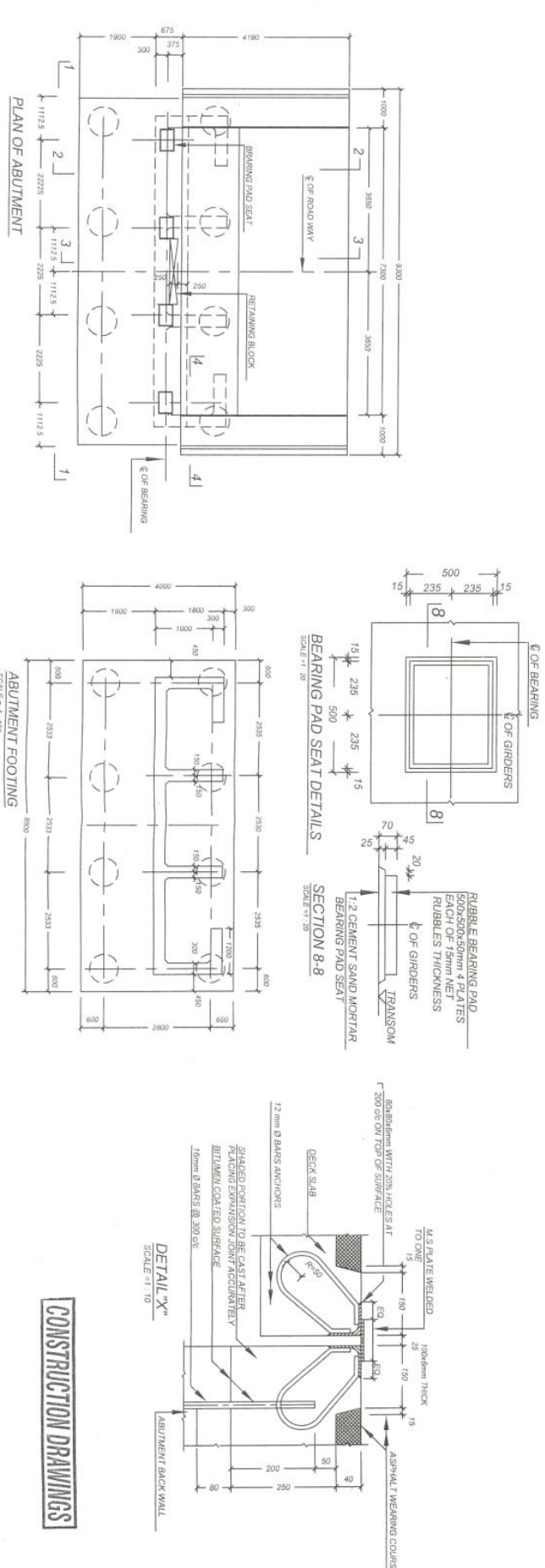
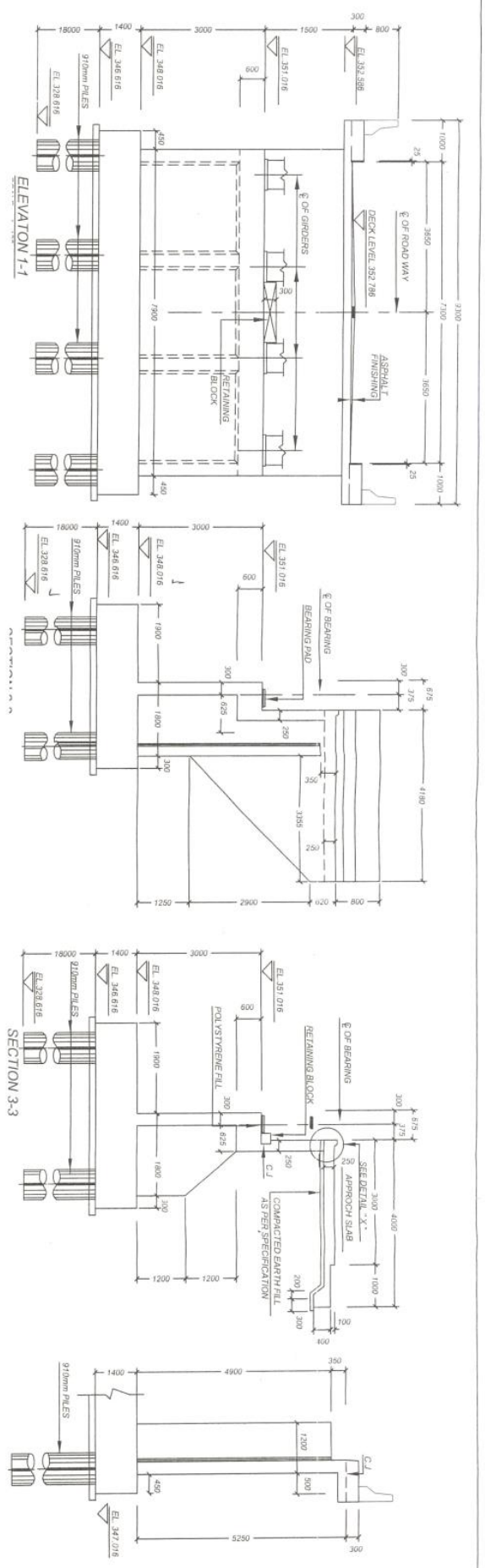

G.O.T OF KHYBER PAKHTUNKHWA
IRRIGATION DEPARTMENT CHARASADA

D M C
Development Management Consultants
Consulting Engineers, Economists, Planners & Management Scientists
OFFICE No. 24, 2nd Floor, Commercial Plaza, Saidu Sharif, Peshawar, Khyber Pakhtunkhwa
Phone: (+92) 31257888, 578919 Fax: (+92) 31 577891 Email: dmc@devmg.com

REV	DATE	REVISIONS	DRAWN	SCALE
01		DESIGNED	M. SIDDIQUE	1 : 100
02		CHECKED	SHEHZAD AHMAD	
03		APPROVED		

CONSTRUCTION DRAWINGS

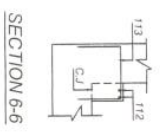
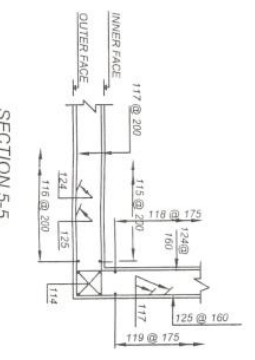
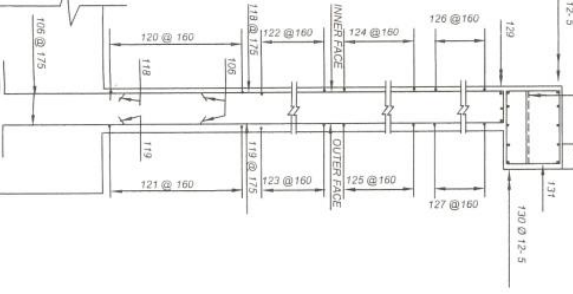
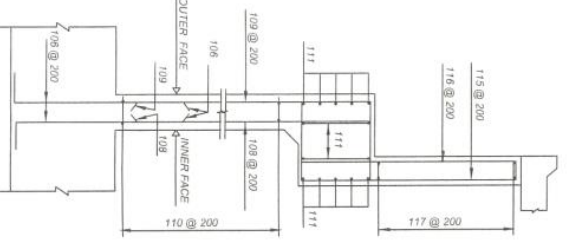
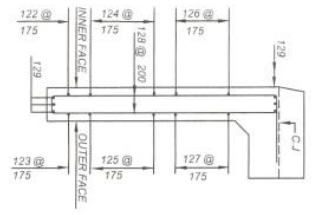
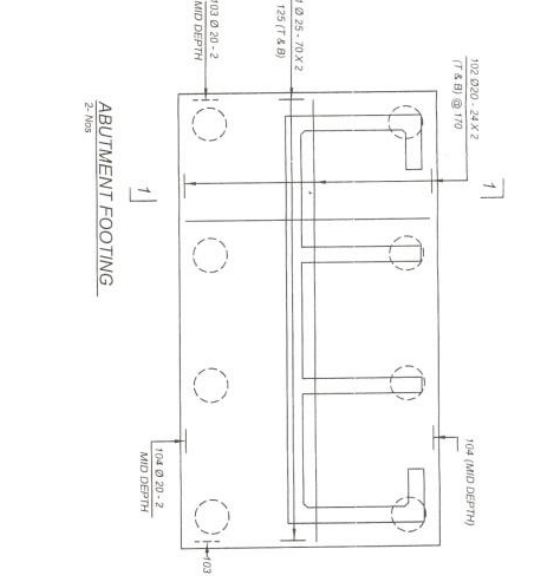
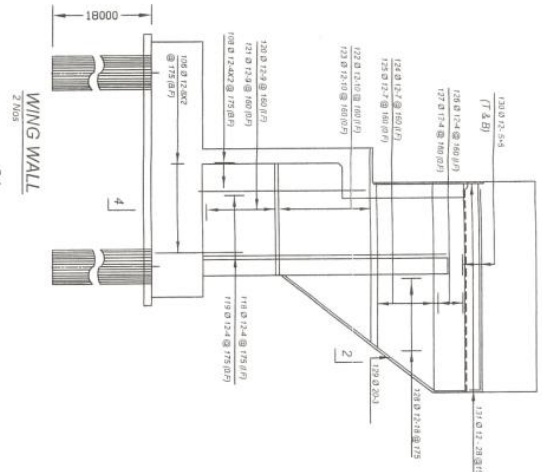
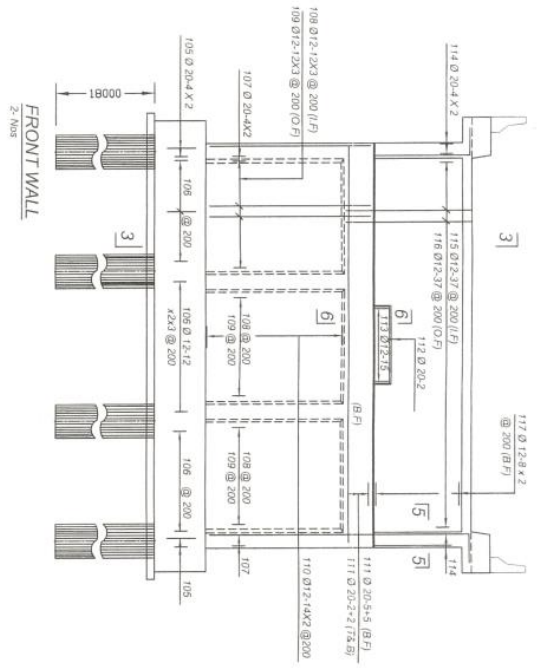

CONSTRUCTION DRAWINGS

GOVT OF KHBER PAKHTUNKHWA
IRRIGATION DEPARTMENT CHARSAADA

DMC
Development Management Consultants
Consulting Engineers, Economists, Planners & Management Specialists
Punjab Road, Faisalabad, Pakistan
Phone: +92-41-3727900, 3728019 Fax: +92-41-3728018 Email: dmcc@dmcc.gov.pk

REV	DATE	REVISIONS	DRAWN	SCALE
01			MABI AMIN	
02			DESIGNED M. SIDDIQUE	
03			CH/OWNER SHEHZAD AHMAD	
			APPROVED	1 / 100

BAR BENDING SCHEDULE FOR ABUTMENT

LOCATION	CODE	DIA (mm)	NO.	TOTAL LENGTH (mm)	BENDING SCHEDULE
PILE CAPS (2 Nos)	101	Ø 25	118	236	a = 3000 b = 550
	102	Ø 20	4	80	a = 8700 b = 300
	103	Ø 20	2	40	STRAIGHT
	104	Ø 20	2	40	STRAIGHT
	105	Ø 20	8	160	a = 8700 b = 300
	106	Ø 12	72	864	a = 1430
	107	Ø 20	8	160	STRAIGHT
	108	Ø 12	36	432	STRAIGHT
	109	Ø 12	36	432	STRAIGHT
	110	Ø 12	28	336	a = 1720 b = 200
FRONT WALLS (2 Nos)	111	Ø 20	14	280	a = 1720 b = 300
	112	Ø 20	2	40	a = 1720 b = 300
	113	Ø 12	15	180	a = 1720 b = 300
	114	Ø 20	8	160	a = 1720 b = 300
	115	Ø 12	32	384	a = 1720 b = 300
	116	Ø 12	32	384	a = 1720 b = 300
	117	Ø 12	16	192	a = 1720 b = 300
	118	Ø 12	16	192	a = 1720 b = 300
	119	Ø 12	8	96	a = 1720 b = 300
	120	Ø 12	4	48	a = 1720 b = 300
WING WALLS (4 Nos)	121	Ø 12	9	108	a = 1720 b = 300
	122	Ø 12	9	108	a = 1720 b = 300
	123	Ø 12	11	132	a = 1720 b = 300
	124	Ø 12	7	84	a = 1720 b = 300
	125	Ø 12	4	48	a = 1720 b = 300
	126	Ø 12	4	48	a = 1720 b = 300
	127	Ø 12	18	216	a = 1720 b = 300
	128	Ø 12	18	216	a = 1720 b = 300
	129	Ø 20	3	60	a = 1720 b = 300
	130	Ø 12	10	120	a = 1720 b = 300
COUNTERFORT (C.F - 1) (4 Nos)	131	Ø 12	28	336	a = 1720 b = 300
	132	Ø 12	8	96	a = 1720 b = 300
	133	Ø 12	2	24	a = 1720 b = 300
	134	Ø 12	2	24	a = 1720 b = 300
	135	Ø 20	3	60	a = 1720 b = 300
	136	Ø 20	3	60	a = 1720 b = 300
	137	Ø 25	4	100	a = 1720 b = 300
	138	Ø 12	18	216	a = 1720 b = 300
	139	Ø 12	8	96	a = 1720 b = 300
	140	Ø 12	70	840	a = 1720 b = 300
COUNTERFORT (C.F - 2) (4 Nos)	141	Ø 12	8	96	a = 1720 b = 300
	142	Ø 12	8	96	a = 1720 b = 300
	143	Ø 12	4	48	a = 1720 b = 300
	144	Ø 20	4	80	a = 1720 b = 300
	145	Ø 20	4	80	a = 1720 b = 300
	146	Ø 12	12	144	a = 1720 b = 300
	147	Ø 12	28	336	a = 1720 b = 300
	148	Ø 12	12	144	a = 1720 b = 300
	149	Ø 12	12	144	a = 1720 b = 300
	150	Ø 12	12	144	a = 1720 b = 300
APPROACH SLAB (2 Nos)	151	Ø 12	49	588	a = 1720 b = 300
	152	Ø 12	22	264	a = 1720 b = 300
	153	Ø 25	519	6225	a = 1720 b = 300
	154	Ø 12	1	12	a = 1720 b = 300
	155	Ø 12	1	12	a = 1720 b = 300
	156	Ø 12	49	588	a = 1720 b = 300
	157	Ø 12	22	264	a = 1720 b = 300
	158	Ø 12	22	264	a = 1720 b = 300
	159	Ø 12	1	12	a = 1720 b = 300
	160	Ø 12	1	12	a = 1720 b = 300

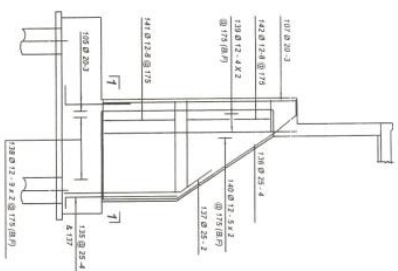

COUNTERFORT C.F-1
4 Nos

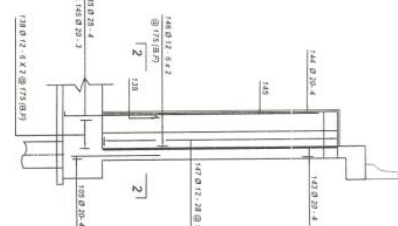

COUNTERFORT C.F-2
4 Nos

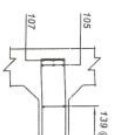

SECTION 1-1

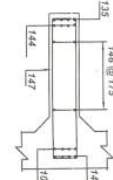

SECTION 2-2

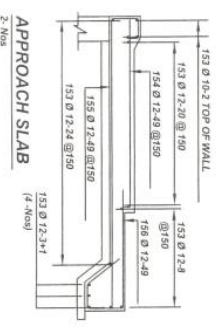

APPROACH SLAB
(4 Nos)

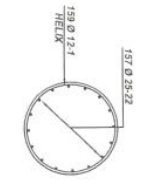

SECTION 6-6
SCALE = 1:20

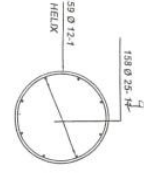

SECTION 7-7
SCALE = 1:20

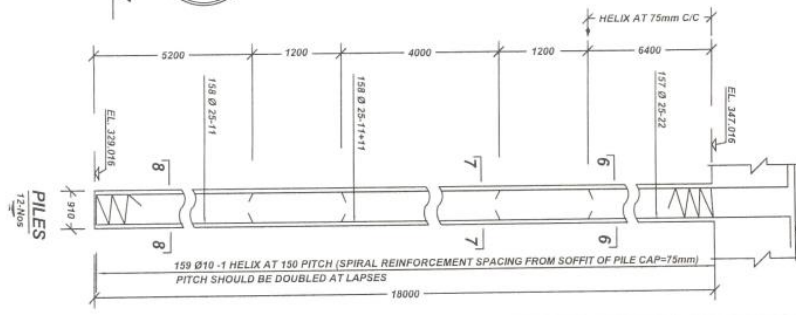

PILES
13 Nos

CONSTRUCTION DRAWINGS

GOVT OF KHBER PAKHTUNKHWA
IRRIGATION DEPARTMENT CHARASADA



Development Management Consultants
Consulting Engineers, Economists, Planners & Management Specialists
Punjab Road, Charasada, Faisalabad, Pakistan
Phone: +92 372 770000, 3250707 Fax: +92 372 770001 E-mail: dmc@dmcc.com

REV	DATE	REVISIONS	DRAWN	SCALE
01		DESIGNED	M. SIDDIQUE	1:100
02		CHANGED	SHEHZAD AHMAD	
03		APPROVED		

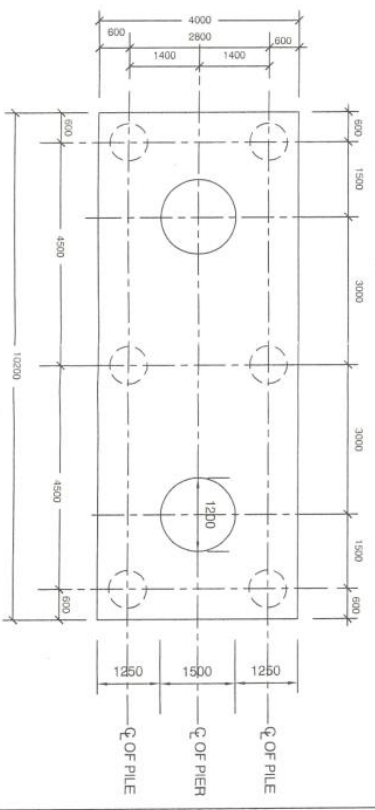
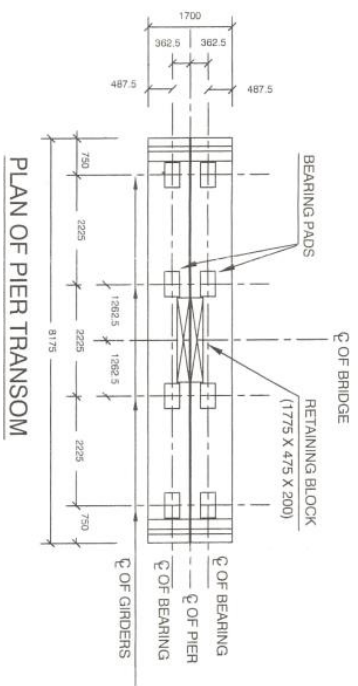
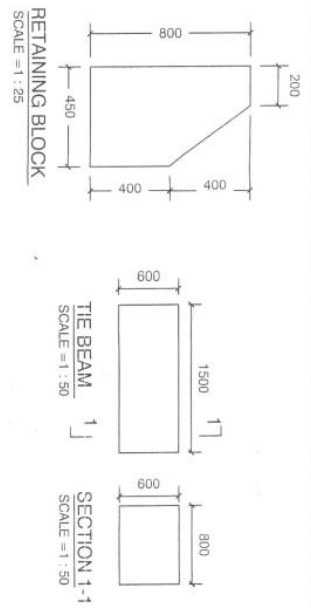
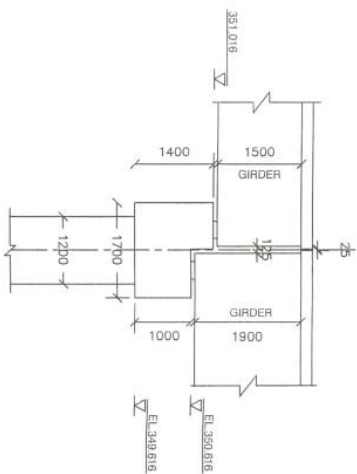
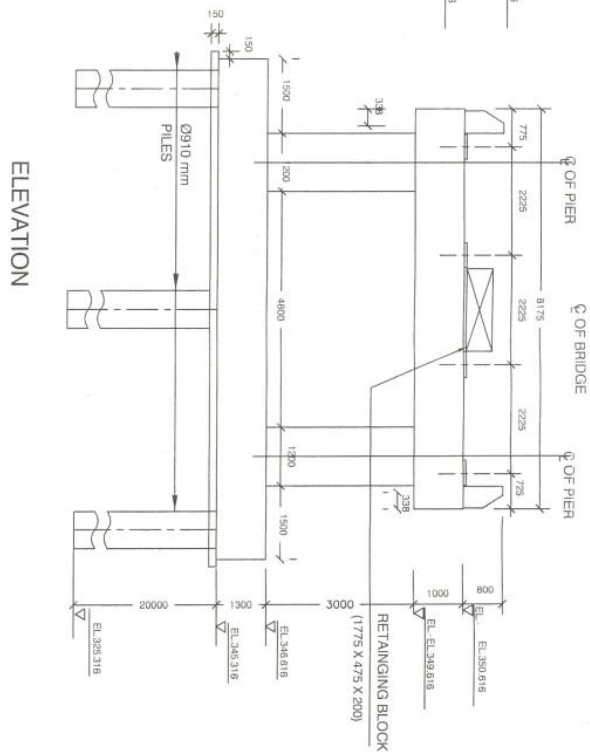
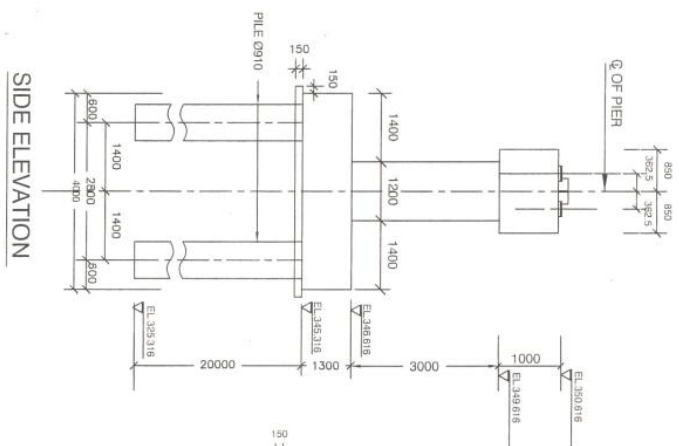

PIER 01 & PIER 04 TRANSOM ELEVATION VIEW

PLAN OF FOUNDATION

CONSTRUCTION DRAWINGS

REV	DATE	REVISIONS	DRAWN	CHECKED	APPROVED	SCALE
01			NABI AMIN	M SIDDIQ		
02			CH/OVER	SHANAZAD		
03			APPROVED			1 : 100

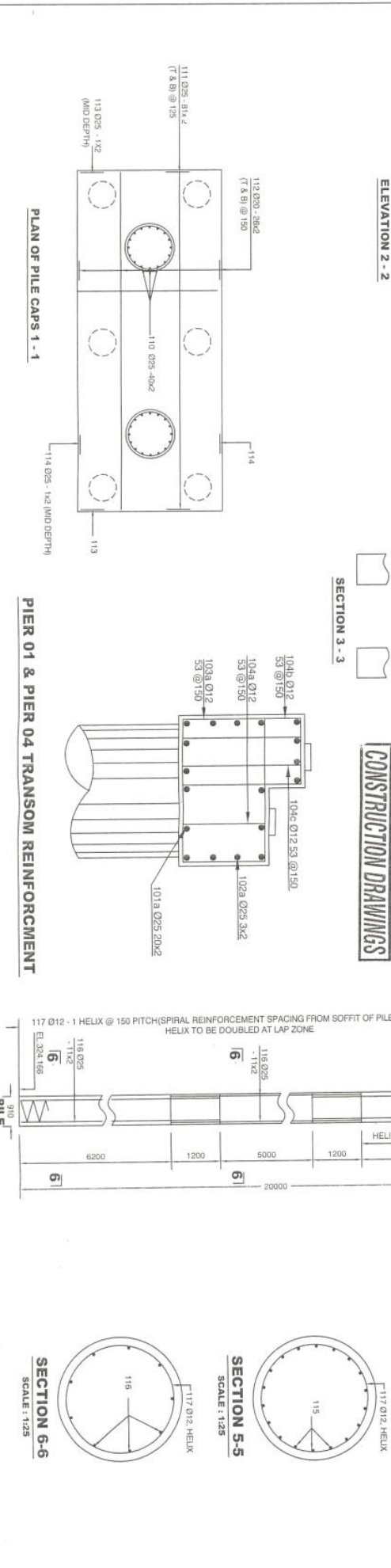
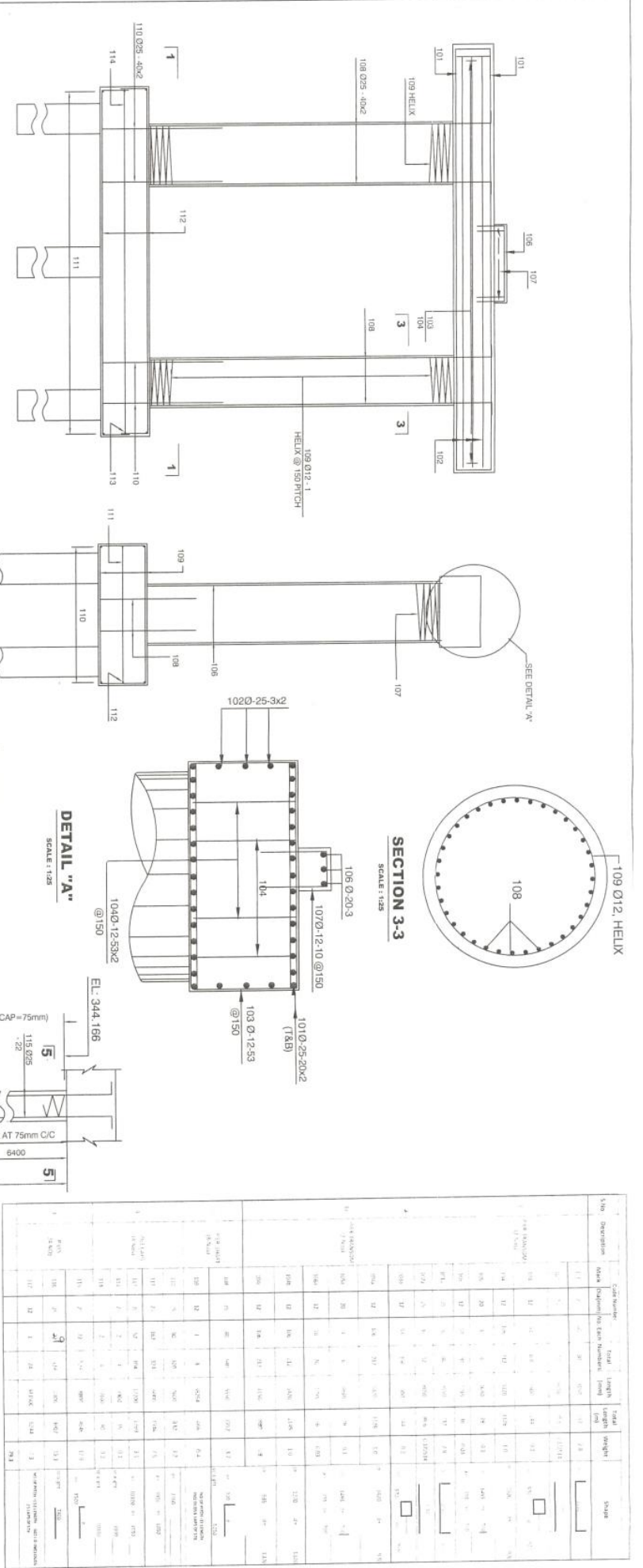

REV	DATE	REVISIONS	DRAWN	DESIGNED	CHK/VEH	APPROVED	SCALE
01			NAJI AMIN	M.SIDDIQ	SHARAZD		1 : 100
02							
03							

GOVT OF KHYBER PAKHTUNKHWA
IRRIGATION DEPARTMENT CHARASADA

DMC

Development Management Consultants
Consulting Engineers, Economists, Planners & Management Specialists
Office: 192, 204, 205, F-7/2, Phase-7, Islamabad
Phone: +92 (0) 343 999 5500 Fax: +92 (0) 343 999 5501 Email: dmcc@dmcc.com

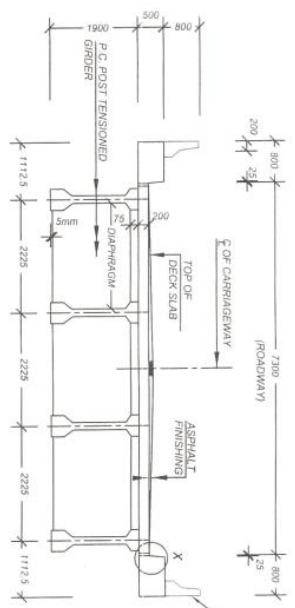

CROSS SECTION
SCALE 1:100

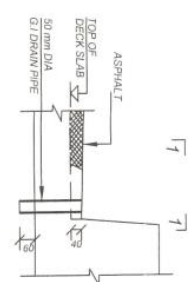

DETAIL (X)
TYPICAL DETAIL OF DRAIN PIPE
SCALE 1:20

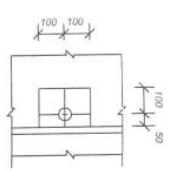

PLAN 1-1
SCALE 1:20

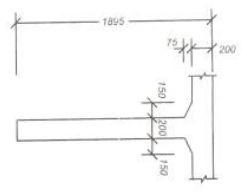

SECTION 5-5
SCALE 1:50

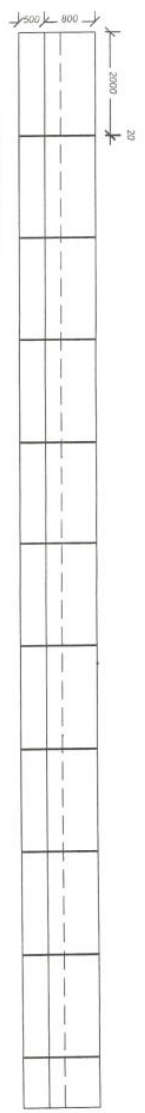

ELEVATION 4-4
SCALE 1:150

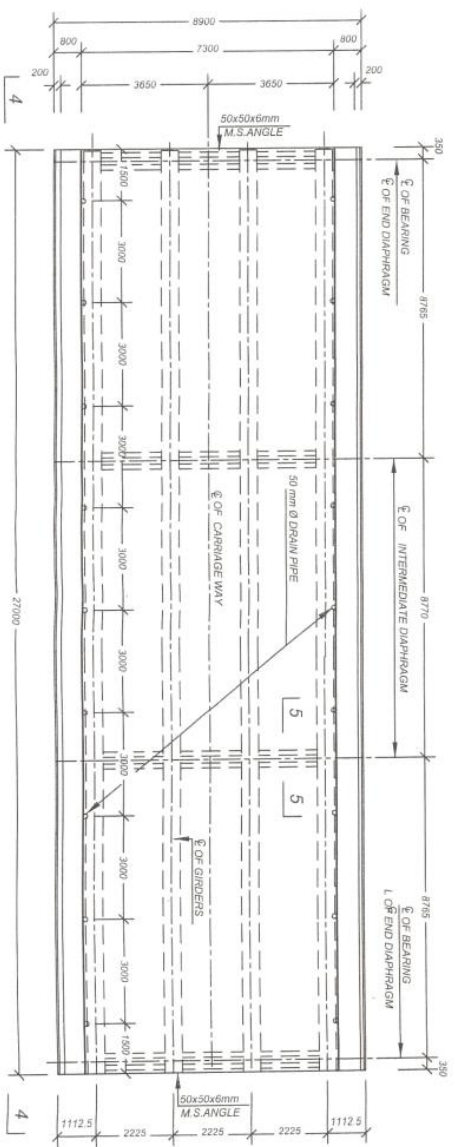

PLAN OF DECK SLAB
SCALE 1:150

CONSTRUCTION DRAWINGS

GOVT OF KHUBER PAKHTUNKHWA
IRRIGATION DEPARTMENT CHARASADA



Development Management Consultants
117-B, 6th floor, Commercial Plaza, Saidu Road, Bahawalpur, Pakistan
Phone: (99-91) 9378800, 9378801 Fax: (99-91) 9378811 Email: dmcc@dmcc.com

REV	DATE	REVISIONS	DRAWN	DESIGNED	CHECKED	APPROVED	SCALE
01				M. SIDDIQUE			
02			CHADVER	SHERAZD AHMAD			1 : 100
03							

BAR BENDING SCHEDULE

LOCATION	CODE NUMBER		TOTAL		LENGTH mm	TOTAL LENGTH m	BENDING SCHEDULE
	MARK	DIA mm	No. Each	No.			
DECK-SLAB (7 Nos)	101	Ø 16	238	218	7095	1889	STRAIGHT
	102	Ø 16	238	218	8650	2106	STRAIGHT
	103	Ø 12	718	138	27910	3024	STRAIGHT (length includes 2 nos of 480)
	104	Ø 12	390	360	3065	1103	STRAIGHT
DIAPHRAGMS END 2 Nos	105	Ø 16	3	12	8650	106	STRAIGHT
	106	Ø 12	18	72	1750	126	STRAIGHT c = 1835 d = 150
	107	Ø 12	36	144	4210	606	IN SIDE DIMENSIONS
					Ø 20	Ø 25	TOTAL (K/G)
					4659	3971	M.S
					4315	8162	C.M.S
							10477

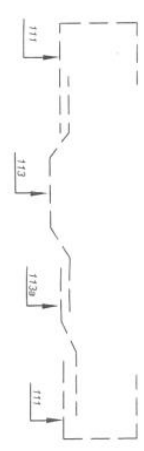
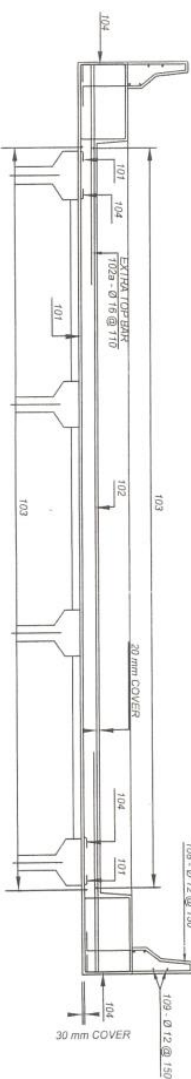
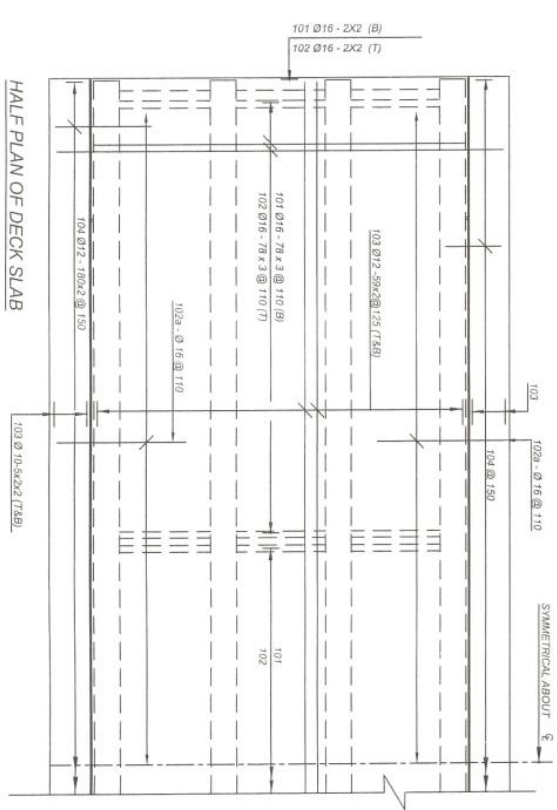
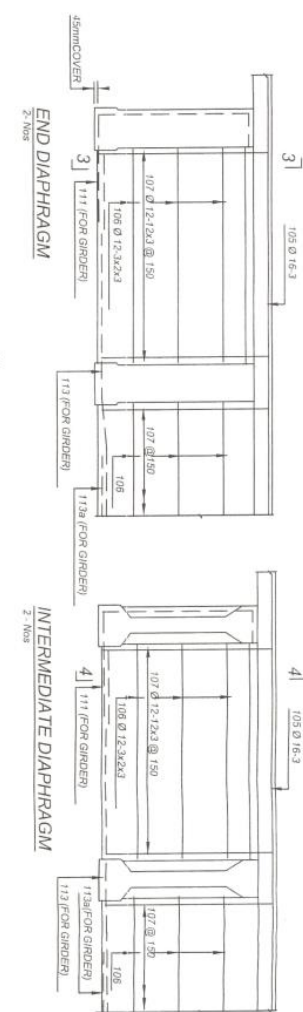

CONSTRUCTION DRAWINGS

GOVT OF KHBER PAKHTUNKHWA
IRRIGATION DEPARTMENT CHARSADA

DMC Development Management Consultants
Office: 1st and 2nd Floor, Charsada, F-10/1, Islamabad
Phone: (03) 9127880, 4270073 Fax: (03) 91 517891 Email: dmcc@dmcc.gov.pk

REV	DATE	REVISIONS	DRAWN	NABI AMIN	SCALE
01		DESIGNED	M. SIDDIQUE		
02		CHECKED	SHEHZAD AHMAD		1 : 100
03		APPROVED			

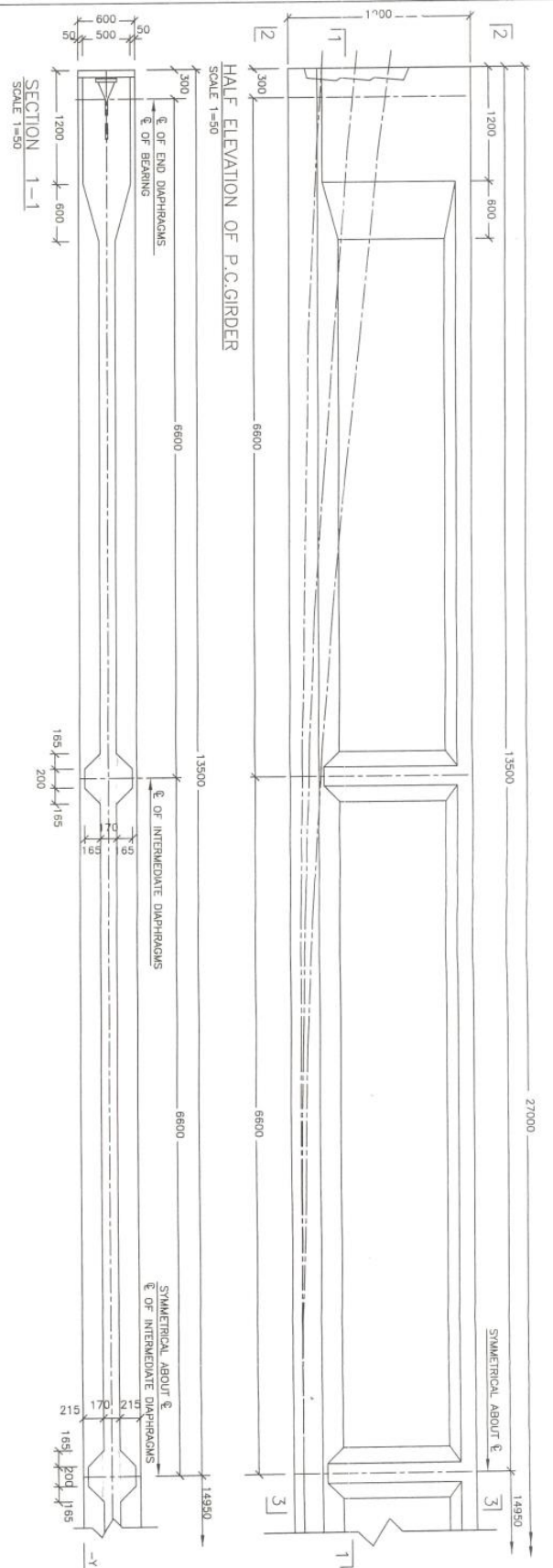

REFERENCE CO-ORDINATES

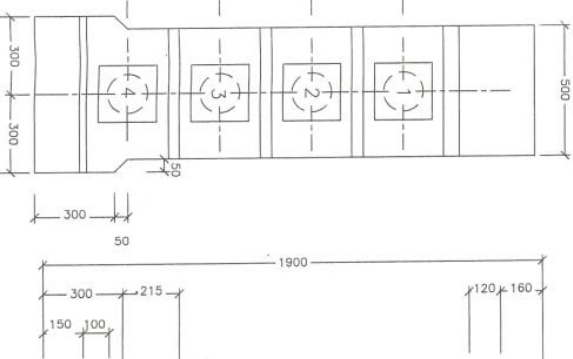
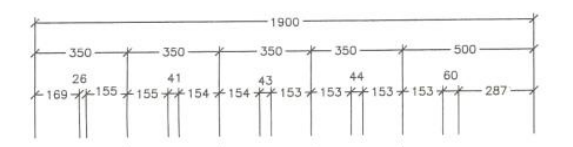
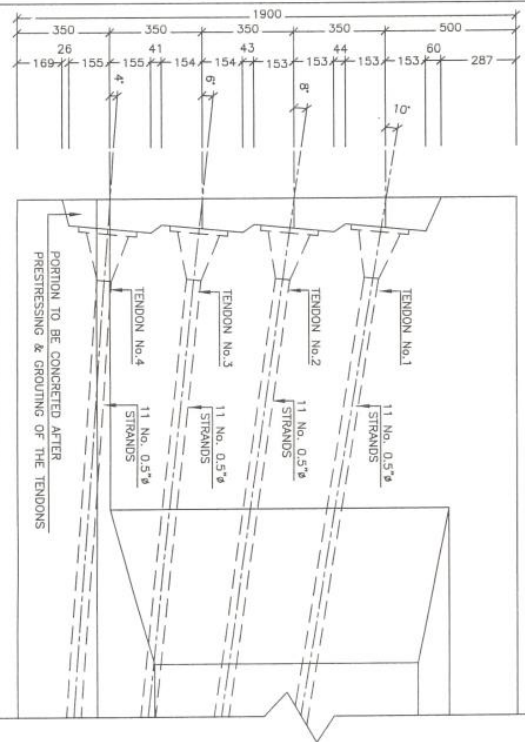

TENDON DATA

CABLE No.	ORDINATE FROM C				TOTAL ELONGATION ORDER OF STRESSING
	1	2	3	4	
AT &	Y	Z	Y	Z	
1500	0	250	0	190	-100 150 100 150
3000	0	294	0	153	-100 150 100 150
4500	0	271	0	165	-75 153 75 150
6000	0	308	0	193	-75 161 75 150
7500	0	369	0	239	-50 179 50 150
9000	0	489	0	308	-50 210 50 151
10500	0	580	0	402	-25 259 25 155
12000	0	735	0	523	0 330 0 167
13850	0	930	0	678	0 428 0 195
TOTAL	213	1224	909	595	0 280
ORDER OF STRESSING	A	B	C	D	

CONSTRUCTION DRAWINGS

GOVT OF KHYBER PAKHTUNKHWA
IRRIGATION DEPARTMENT CHARSHADA

Development Management Consultants
D M C
Consulting Engineers, Surveyors, Planners & Management Specialists
Office No. 4, and Plot, Cantonment Area, Sidiqi Road, Peshawar
Phone: 3746346/347, 3746345/348, 3746344/349, 3746343/350 Fax: 3746344/349, 3746345/350 Email: dmcc@pki.com

REV	DATE	REVISIONS	DRAWN	DESIGNED	CHECKED/VER	APPROVED	SCALE
01				M. SIDDIQUE			
02				CHD/VER	SHEHZAD AHMAD		
03				APPROVED			1 : 100

35

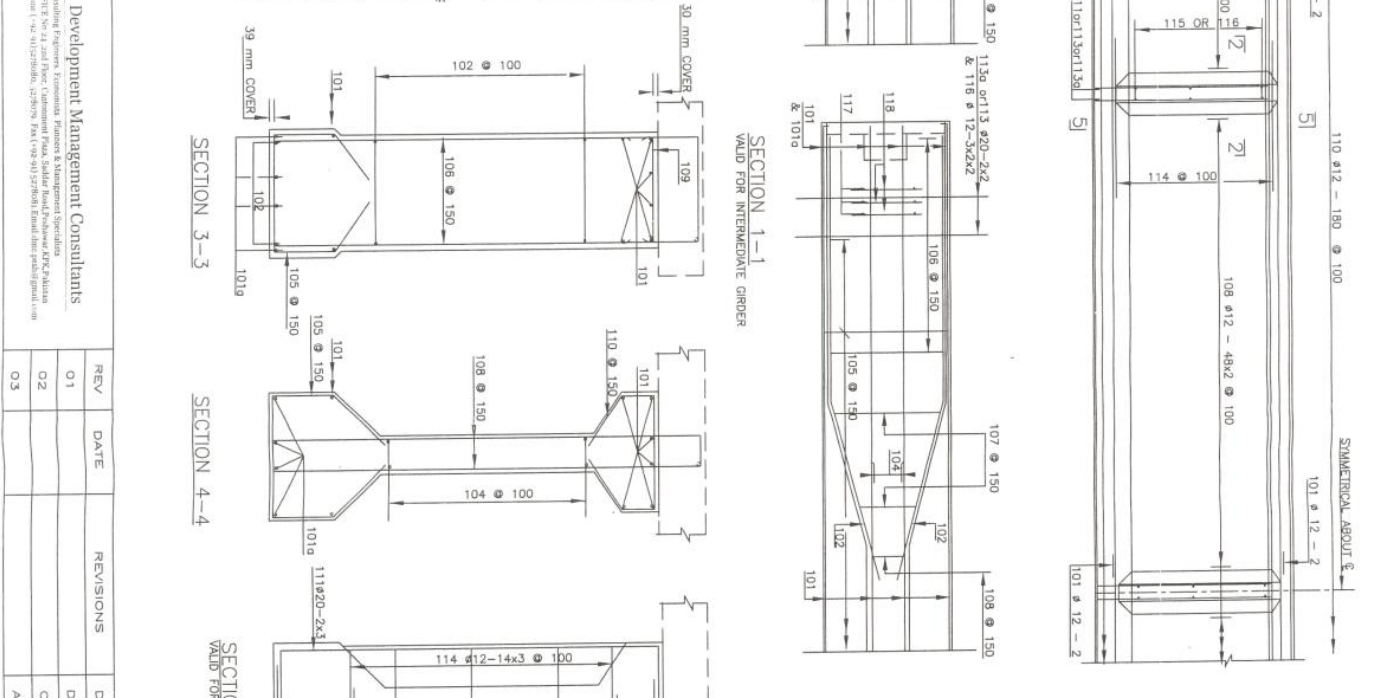
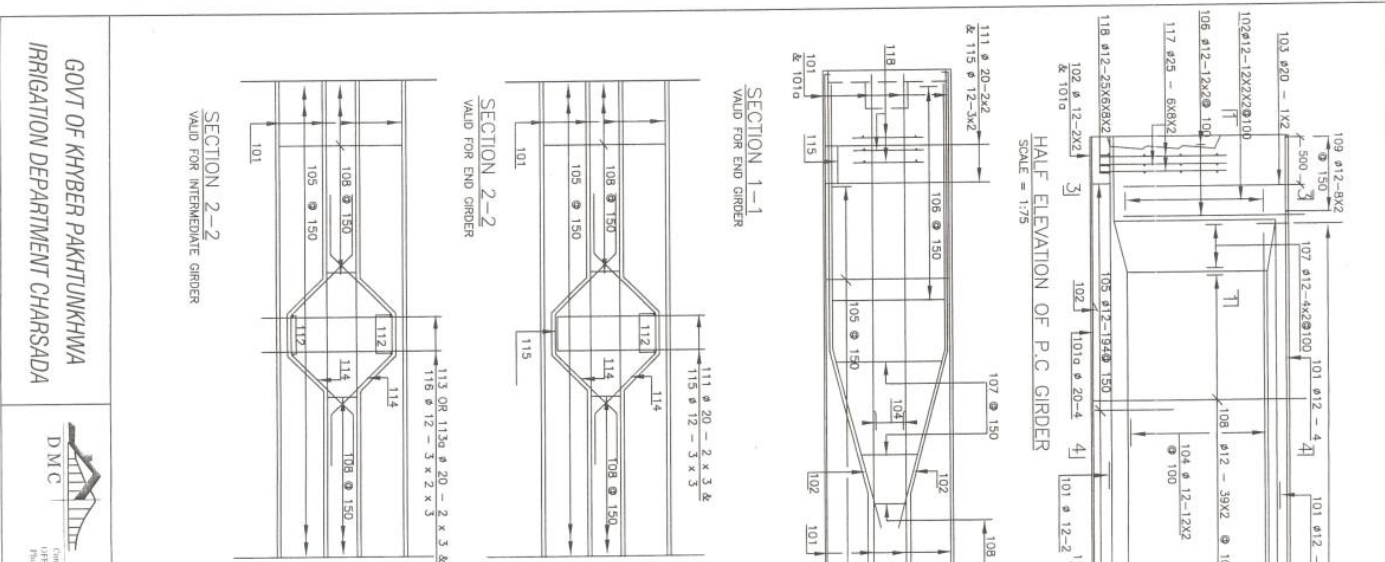

BAR BENDING SCHEDULE

LOCATION	CODE	NUMBER	TOTAL	LENGTH	TOTAL	BENDING SCHEDULE
	MARK	Dia. mm	Each	mm	m	
P.C GIRDERS	101	12	48	31290	1502	STRAIGHT (length includes 3 laps of 576)
	101a	20	4	32730	524	STRAIGHT (length includes 3 laps of 986)
	102	12	48	2080	192	1220 $\frac{2080}{150}$ 150 L 2005 r=150
	103	20	2	4480	88	LIFTING HOOK 150
END 2 Nos.	104	12	24	28340	2721	STRAIGHT (length includes 3 laps of 486)
	105	12	194	776	1800	1397
INTERMEDIATE 2 Nos.	106	12	12	48	5150	c = 2025 d = 430 d ₂ = 367.5 550 1275
	107	12	8	32	4390	d min = 220
BAR BENDING SCHEDULE	108	12	174	696	4390	c = 2025 d = 120
	109	12	18	64	680	44
	110	12	180	720	1240	893
	111	20	10	20	3715	74
	112	12	612	36	2815	94
	113	20	10	10	3850	39
	114	12	108	432	1900	648
	115	12	15	30	2250	68
	116	12	30	60	1652	100
	117	25	36	144	1345	194
	118	25	96	384	450	173
	119	20	10	10	3225	33
	120	25	10	10	1885	240

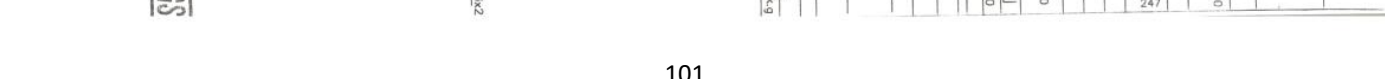

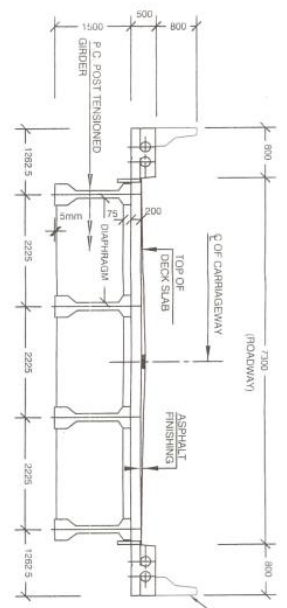

NOTE
NEW JERSEY BARRIER EACH PANEL WILL BE 2m IN LENGTH HAVING EXPANSION JOINT OF 20mm AT EACH 80m INTERVAL.

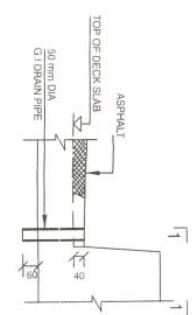

DETAIL (X)
TYPICAL DETAIL OF DRAIN PIPE
SCALE 1:50

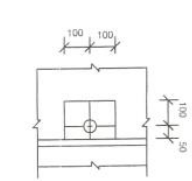

PLAN 1-1
SCALE 1:50

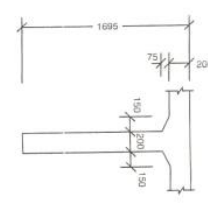

SECTION 5-5
SCALE 1:50

ELEVATION 4-4
SCALE 1:50

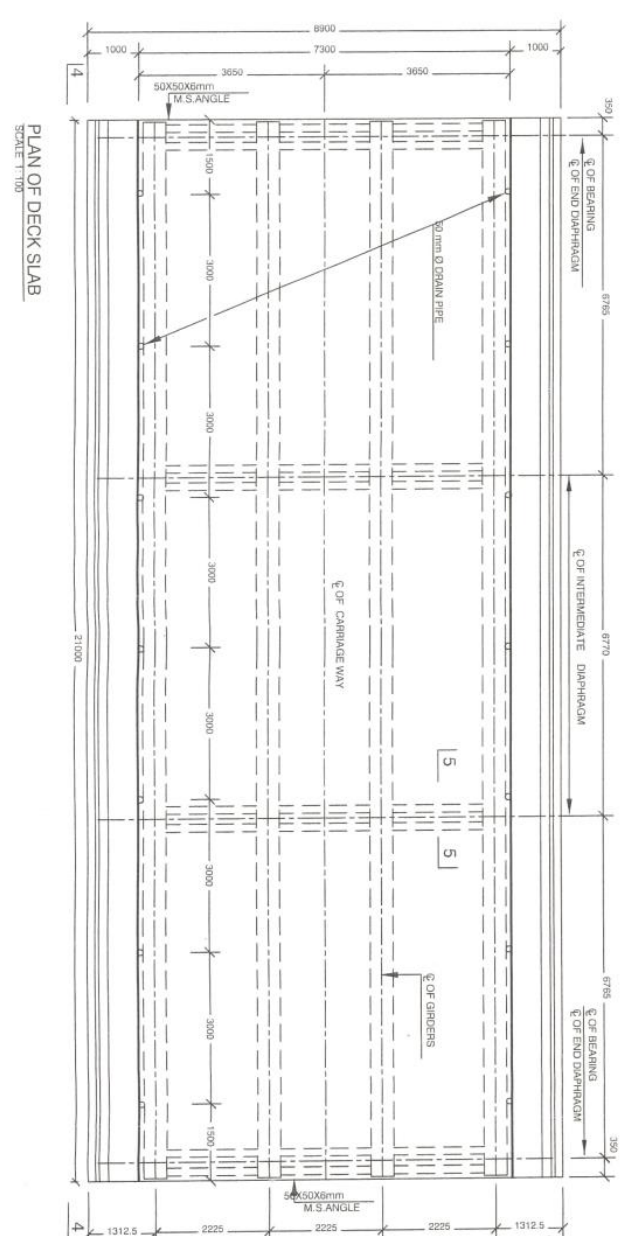

PLAN OF DECK SLAB
SCALE 1:100

CONSTRUCTION DRAWINGS

GOVT OF KHYBER PAKHTUNKHWA
IRRIGATION DEPARTMENT CHARSAIDA

D M C
Development Management Consultants
Office No 24 2nd Floor, Carpenter Plaza, Saddar Road, Peshawar
Phone: (030) 9102800, 9270271 Fax: (030) 9102801 Email: dmcc@dmcc.com

REV	DATE	REVISIONS	DRAWN	DESIGNED	CHECKED	APPROVED	SCALE
01			NABI AMIN	M. SIDDIQUE			1 : 100
02				CH/OVER	SHENHAZD AHMAD		
03							

REV	DATE	REVISIONS	DRAWN	DESIGNED	CHECKED	APPROVED
01			NABI AMIN	M. SIDDIQUE		
02				SHEHZAD AHMAD		
03						

SCALE
1 : 100

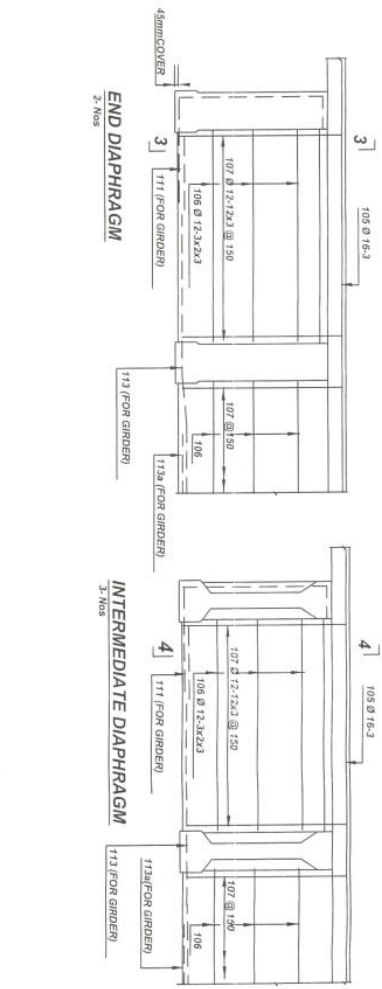
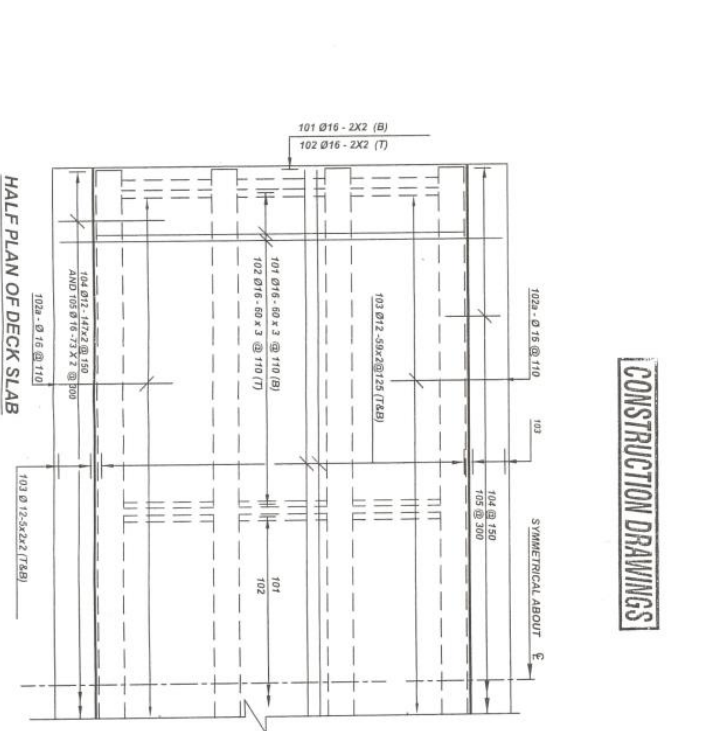
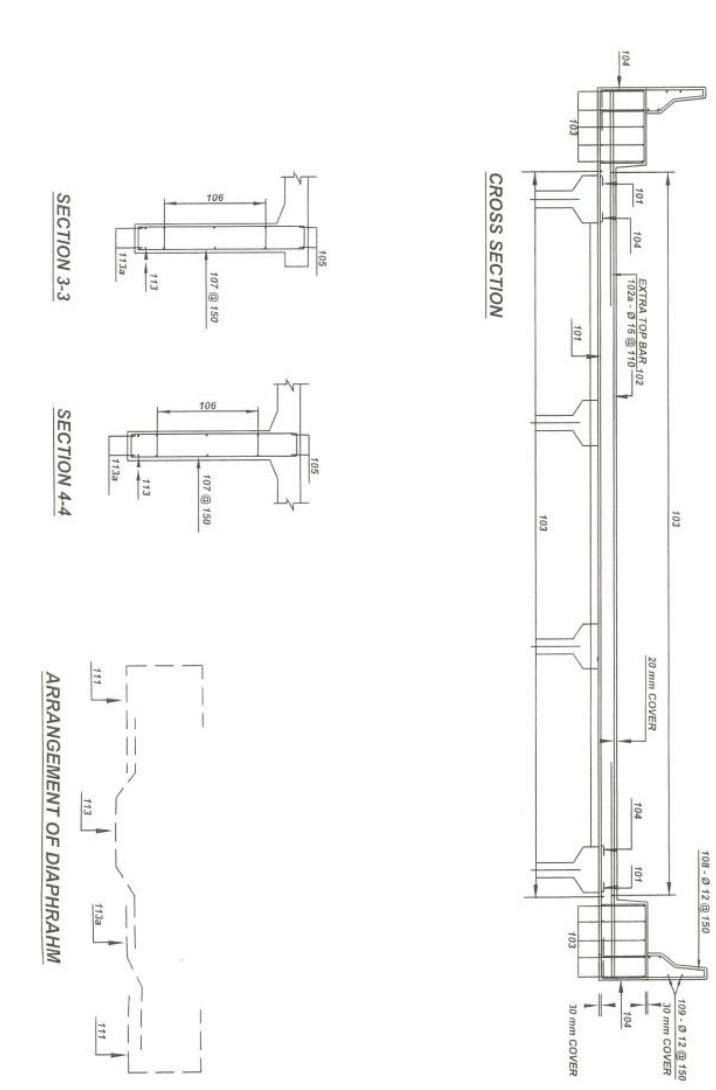

BAR BENDING SCHEDULE

LOCATION	CODE NUMBER			TOTAL LENGTH mm	TOTAL LENGTH m	BENDING SCHEDULE			
	MARK	DIA mm	No.						
DECK SLAB (1-Nos)	101	Ø 16	184	7095	7.095	STRAIGHT			
	102	Ø 16	184	8850	8.850	STRAIGHT			
	103	Ø 12	138	27910	27.910	STRAIGHT (length includes 2 laps of 480)			
	104	Ø 12	280	3065	3.065	STRAIGHT			
DIAPHRAGMS END (2-Nos)	105	Ø 16	3	8850	8.850	STRAIGHT			
	106	Ø 12	18	1750	1.750	STRAIGHT			
	107	Ø 12	36	3810	3.810	STRAIGHT			
				144	549	IN SIDE DIMENSIONS			
				Ø 10	Ø 12	Ø 16	Ø 20	Ø 25	TOTAL (K.G)
				4558	3039	4796	-	-	M.S
				4048	4796	-	-	-	C.I.W.S
				-	-	-	-	-	8844

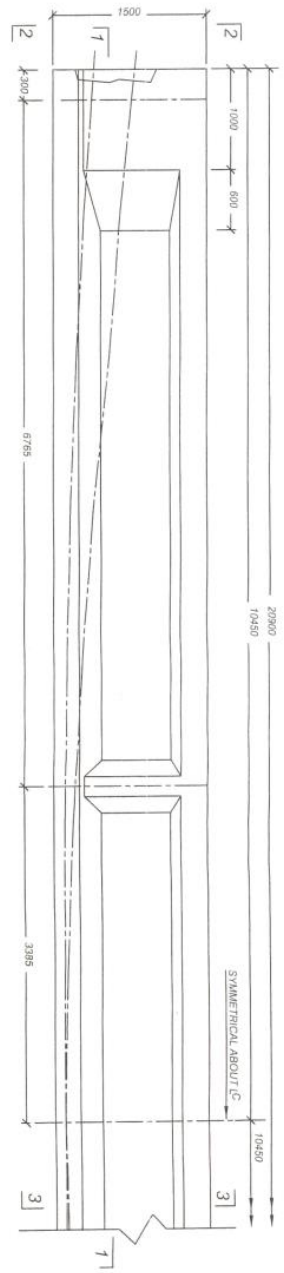

HALF ELEVATION OF P.C. GIRDER
SCALE 1=50

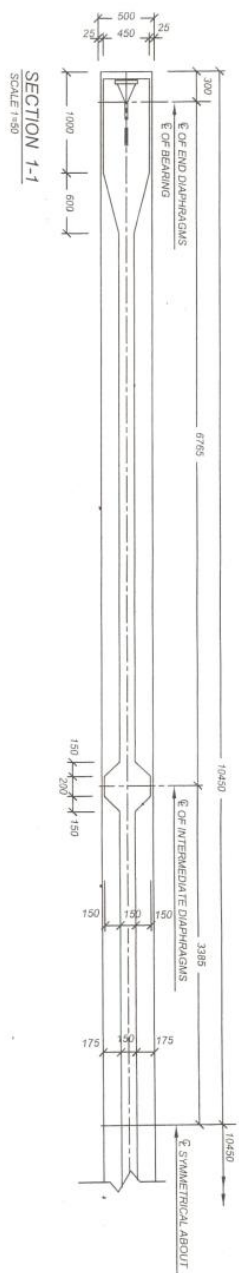

SECTION 1-1
SCALE 1=50

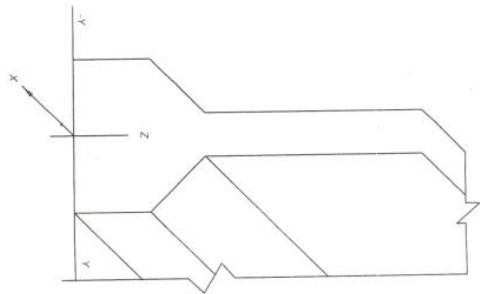

REFERENCE CO-ORDINATES

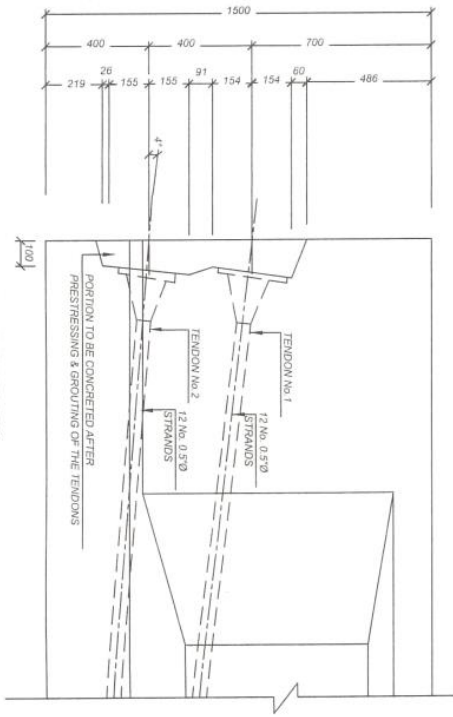

DETAIL OF END BLOCK
(SHOWING POSITION OF CABLE ANCHORAGES)
SCALE 1=20

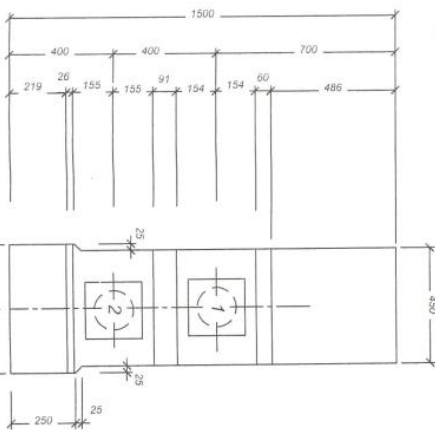

ELEVATION 2-2
SCALE 1=20

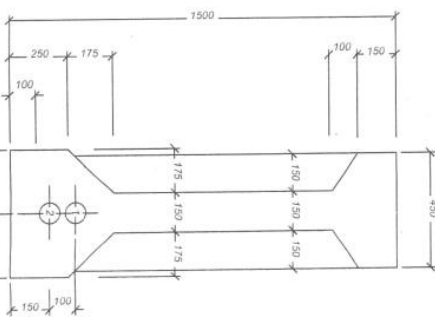

SECTION 3-3
SCALE 1=20

CABLE No	TENDON DATA			
	1	2	1	2
ORDINATE FROM G	V	Z	V	Z
AT G	0	250	0	150
1500	0	258	0	150
3000	0	286	0	153
4500	0	338	0	153
6000	0	365	0	170
7500	0	417	0	185
9000	0	523	0	224
TOTAL ELONGATION	0	659	0	307
ORDER OF STRESSING	0	693	0	330
	149		150	

CONSTRUCTION DRAWINGS

GOVT OF KHYBER PAKHTUNKHWA
IRRIGATION DEPARTMENT CHARSADA

DMC
Development Management Consultants
Consulting Engineers, Economists, Planners & Management Specialists
Project Management, Construction Management, Feasibility Studies, Environmental Impact Assessment, Urban Planning, Surveying, Water Resources, Irrigation, Road & Airport Construction, Rehabilitation, Maintenance & Management of Infrastructure Assets.
Head Office: 27, 28, 29, 30, 31, 32, 33, 34, 35, 36, 37, 38, 39, 40, 41, 42, 43, 44, 45, 46, 47, 48, 49, 50, 51, 52, 53, 54, 55, 56, 57, 58, 59, 60, 61, 62, 63, 64, 65, 66, 67, 68, 69, 70, 71, 72, 73, 74, 75, 76, 77, 78, 79, 80, 81, 82, 83, 84, 85, 86, 87, 88, 89, 90, 91, 92, 93, 94, 95, 96, 97, 98, 99, 100, 101, 102, 103, 104, 105, 106, 107, 108, 109, 110, 111, 112, 113, 114, 115, 116, 117, 118, 119, 120, 121, 122, 123, 124, 125, 126, 127, 128, 129, 130, 131, 132, 133, 134, 135, 136, 137, 138, 139, 140, 141, 142, 143, 144, 145, 146, 147, 148, 149, 150, 151, 152, 153, 154, 155, 156, 157, 158, 159, 160, 161, 162, 163, 164, 165, 166, 167, 168, 169, 170, 171, 172, 173, 174, 175, 176, 177, 178, 179, 180, 181, 182, 183, 184, 185, 186, 187, 188, 189, 190, 191, 192, 193, 194, 195, 196, 197, 198, 199, 200, 201, 202, 203, 204, 205, 206, 207, 208, 209, 210, 211, 212, 213, 214, 215, 216, 217, 218, 219, 220, 221, 222, 223, 224, 225, 226, 227, 228, 229, 230, 231, 232, 233, 234, 235, 236, 237, 238, 239, 240, 241, 242, 243, 244, 245, 246, 247, 248, 249, 250, 251, 252, 253, 254, 255, 256, 257, 258, 259, 260, 261, 262, 263, 264, 265, 266, 267, 268, 269, 270, 271, 272, 273, 274, 275, 276, 277, 278, 279, 280, 281, 282, 283, 284, 285, 286, 287, 288, 289, 290, 291, 292, 293, 294, 295, 296, 297, 298, 299, 300, 301, 302, 303, 304, 305, 306, 307, 308, 309, 310, 311, 312, 313, 314, 315, 316, 317, 318, 319, 320, 321, 322, 323, 324, 325, 326, 327, 328, 329, 330, 331, 332, 333, 334, 335, 336, 337, 338, 339, 340, 341, 342, 343, 344, 345, 346, 347, 348, 349, 350, 351, 352, 353, 354, 355, 356, 357, 358, 359, 360, 361, 362, 363, 364, 365, 366, 367, 368, 369, 370, 371, 372, 373, 374, 375, 376, 377, 378, 379, 380, 381, 382, 383, 384, 385, 386, 387, 388, 389, 390, 391, 392, 393, 394, 395, 396, 397, 398, 399, 400, 401, 402, 403, 404, 405, 406, 407, 408, 409, 410, 411, 412, 413, 414, 415, 416, 417, 418, 419, 420, 421, 422, 423, 424, 425, 426, 427, 428, 429, 430, 431, 432, 433, 434, 435, 436, 437, 438, 439, 440, 441, 442, 443, 444, 445, 446, 447, 448, 449, 450, 451, 452, 453, 454, 455, 456, 457, 458, 459, 460, 461, 462, 463, 464, 465, 466, 467, 468, 469, 470, 471, 472, 473, 474, 475, 476, 477, 478, 479, 480, 481, 482, 483, 484, 485, 486, 487, 488, 489, 490, 491, 492, 493, 494, 495, 496, 497, 498, 499, 500, 501, 502, 503, 504, 505, 506, 507, 508, 509, 510, 511, 512, 513, 514, 515, 516, 517, 518, 519, 520, 521, 522, 523, 524, 525, 526, 527, 528, 529, 530, 531, 532, 533, 534, 535, 536, 537, 538, 539, 540, 541, 542, 543, 544, 545, 546, 547, 548, 549, 550, 551, 552, 553, 554, 555, 556, 557, 558, 559, 560, 561, 562, 563, 564, 565, 566, 567, 568, 569, 570, 571, 572, 573, 574, 575, 576, 577, 578, 579, 580, 581, 582, 583, 584, 585, 586, 587, 588, 589, 590, 591, 592, 593, 594, 595, 596, 597, 598, 599, 600, 601, 602, 603, 604, 605, 606, 607, 608, 609, 610, 611, 612, 613, 614, 615, 616, 617, 618, 619, 620, 621, 622, 623, 624, 625, 626, 627, 628, 629, 630, 631, 632, 633, 634, 635, 636, 637, 638, 639, 640, 641, 642, 643, 644, 645, 646, 647, 648, 649, 650, 651, 652, 653, 654, 655, 656, 657, 658, 659, 660, 661, 662, 663, 664, 665, 666, 667, 668, 669, 670, 671, 672, 673, 674, 675, 676, 677, 678, 679, 680, 681, 682, 683, 684, 685, 686, 687, 688, 689, 690, 691, 692, 693, 694, 695, 696, 697, 698, 699, 700, 701, 702, 703, 704, 705, 706, 707, 708, 709, 710, 711, 712, 713, 714, 715, 716, 717, 718, 719, 720, 721, 722, 723, 724, 725, 726, 727, 728, 729, 730, 731, 732, 733, 734, 735, 736, 737, 738, 739, 740, 741, 742, 743, 744, 745, 746, 747, 748, 749, 750, 751, 752, 753, 754, 755, 756, 757, 758, 759, 760, 761, 762, 763, 764, 765, 766, 767, 768, 769, 770, 771, 772, 773, 774, 775, 776, 777, 778, 779, 780, 781, 782, 783, 784, 785, 786, 787, 788, 789, 790, 791, 792, 793, 794, 795, 796, 797, 798, 799, 800, 801, 802, 803, 804, 805, 806, 807, 808, 809, 810, 811, 812, 813, 814, 815, 816, 817, 818, 819, 820, 821, 822, 823, 824, 825, 826, 827, 828, 829, 830, 831, 832, 833, 834, 835, 836, 837, 838, 839, 840, 841, 842, 843, 844, 845, 846, 847, 848, 849, 850, 851, 852, 853, 854, 855, 856, 857, 858, 859, 860, 861, 862, 863, 864, 865, 866, 867, 868, 869, 870, 871, 872, 873, 874, 875, 876, 877, 878, 879, 880, 881, 882, 883, 884, 885, 886, 887, 888, 889, 890, 891, 892, 893, 894, 895, 896, 897, 898, 899, 900, 901, 902, 903, 904, 905, 906, 907, 908, 909, 910, 911, 912, 913, 914, 915, 916, 917, 918, 919, 920, 921, 922, 923, 924, 925, 926, 927, 928, 929, 930, 931, 932, 933, 934, 935, 936, 937, 938, 939, 940, 941, 942, 943, 944, 945, 946, 947, 948, 949, 950, 951, 952, 953, 954, 955, 956, 957, 958, 959, 960, 961, 962, 963, 964, 965, 966, 967, 968, 969, 970, 971, 972, 973, 974, 975, 976, 977, 978, 979, 980, 981, 982, 983, 984, 985, 986, 987, 988, 989, 990, 991, 992, 993, 994, 995, 996, 997, 998, 999, 1000.

REV	DATE	REVISIONS	DRAWN	NABI AMIN	SCALE
01			DESIGNED	MASOOD	1 : 100
02			CHECKED	SHARAZD	
03			APPROVED		

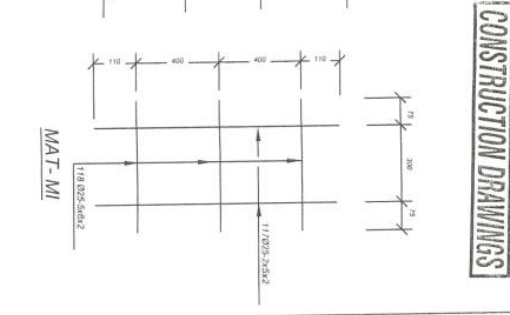
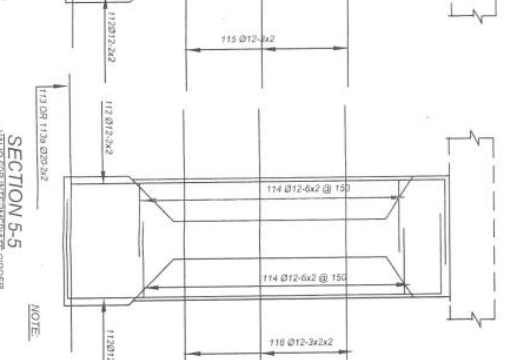
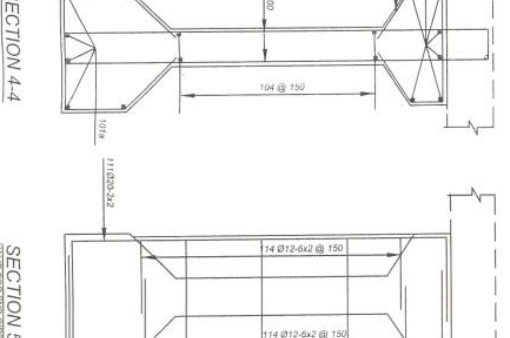
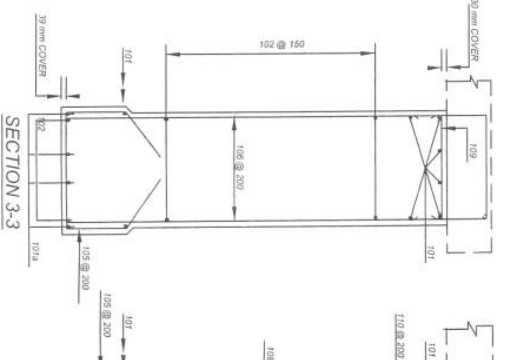
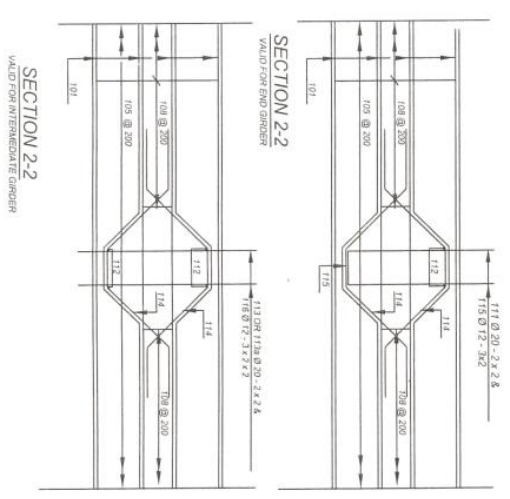
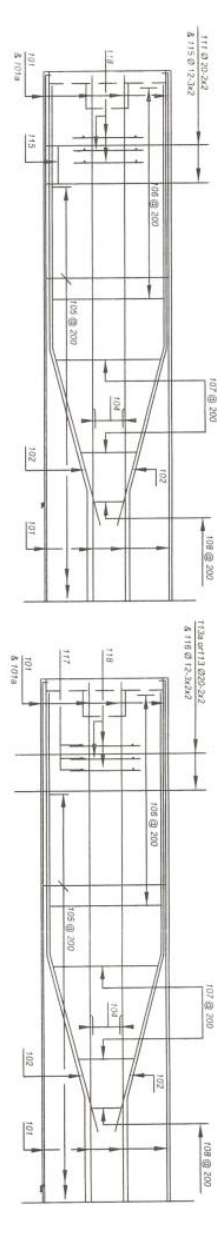
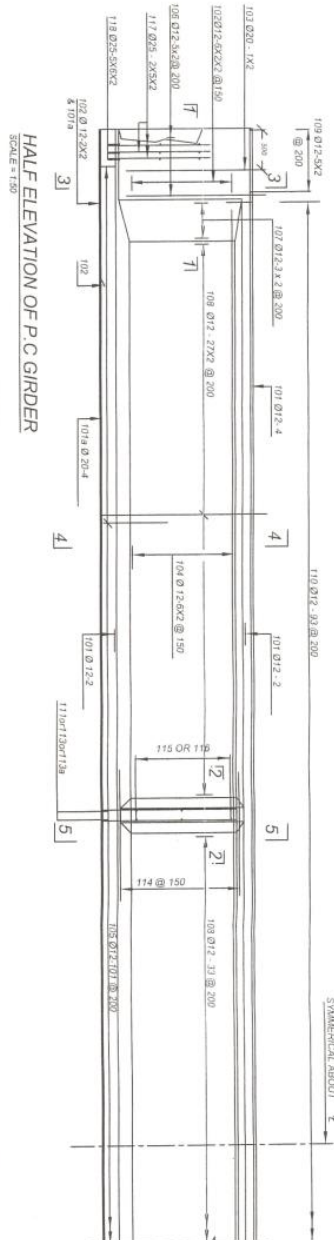

BAR BENDING SCHEDULE

LOCATION	CODE NUMBER	MARK	DIA mm	No. EBD	TOTAL No.	LENGTH mm	TOTAL LENGTH m	BENDING SCHEDULE
P.C GIRDERS	101	Ø 12	8	32	21810	698	364	STRAIGHT (length includes 2 laps of 480)
	102	Ø 12	28	112	1800	202	975	STRAIGHT (length includes 2 laps of 480)
	103	Ø 20	8	9	3735	30	1610	LIFTING HOOK
	104	Ø 12	12	48	19260	924	924	STRAIGHT (length includes 2 laps of 480)
	105	Ø 12	101	404	1480	598	598	
	106	Ø 12	10	40	4290	97	97	
	107	Ø 12	6	24	8080	1284	1284	
	108	Ø 12	87	348	3980	26	26	
	109	Ø 12	10	40	840	424	424	
	110	Ø 12	93	372	1140	53	53	
111	Ø 20	8	16	3225	46	46		
112	Ø 12	4+8	24	1925	46	46		
113	Ø 20	8	8	3980	31	31		
114	Ø 12	24	96	1500	144	144		
115	Ø 12	12	24	2160	52	52		
116	Ø 12	24	48	1572	75	75		
117	Ø 25	12	48	1020	49	49		
118	Ø 25	18	72	450	32	32		
119	Ø 20	8	8	3225	26	26		
		Ø 10	Ø 12	Ø 14	Ø 20	Ø 25	TOTAL (K.G)	
		4742	4213	1244	504	81	M.S	5720
					1244	312	C.W.S	5720

CONSTRUCTION DRAWINGS

MAT - M1

GOVT OF KHAYER PAKHTUNKHWA
IRRIGATION DEPARTMENT CHARASADA

D M C
Development Management Consultants
Consulting Engineers, Estimators, Planners & Management Specialists
Office No. 24, 2nd Floor, Cantonment Plaza, Shalwar Road, Peshawar, P.K. Pakistan
Phone: +92 91 922 0000, 92 91 922 0019, Fax: 92 91 922 0019, Email: dmcc@dmcc.com

REV	DATE	REVISIONS	DRAWN	SCALE
01		DESIGNED	M SADDIQUE	
02		CHECKED	SHAHZAD	1 : 100
03		APPROVED	SHAHZAD	

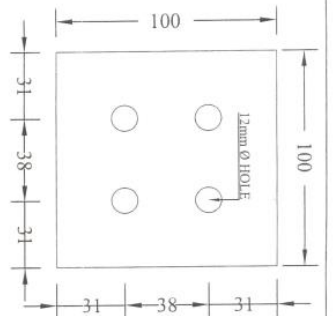

ELEVATION VIEW
NOT TO SCALE

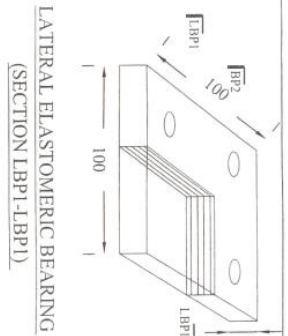

LATERAL ELASTOMERIC BEARING
(SECTION LBP1-LBP1)

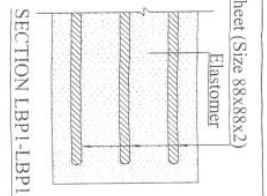

SECTION LBP1-LBP1

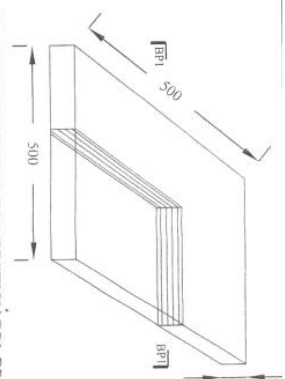

ELASTOMERIC BEARING (SECTION BP1-BP1)

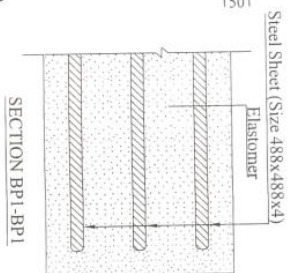

SECTION BP1-BP1

- NOTES :
1. Elastomer hardness 50 ± 5 duro
 2. All dimensions are in millimetre unless otherwise mentioned.
 3. Provide two layer polyethylene sheet between the elastomeric.
 4. Top of bearing seat is to be adjusted according to the longitudinal slope of girder.

- NOTES :
1. Elastomer hardness 50 ± 5 duro
 2. All dimensions are in millimetre unless otherwise mentioned.
 3. Provide two layer polyethylene sheet between the elastomeric.
 4. Top of bearing seat is to be adjusted according to the longitudinal slope of girder.

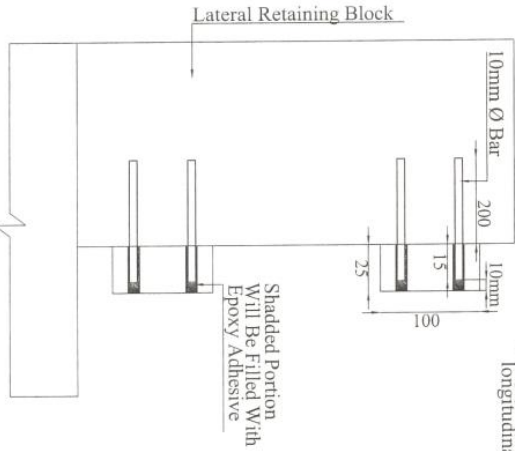

EXPANSION JOINT ANCHOR DETAIL
NOT TO SCALE

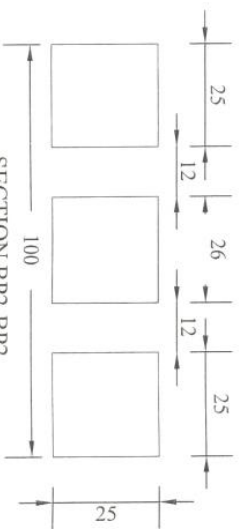

SECTION BP2-BP2
NOT TO SCALE

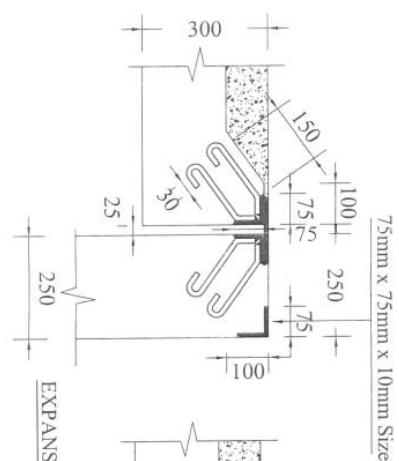

EXPANSION JOINT DETAIL

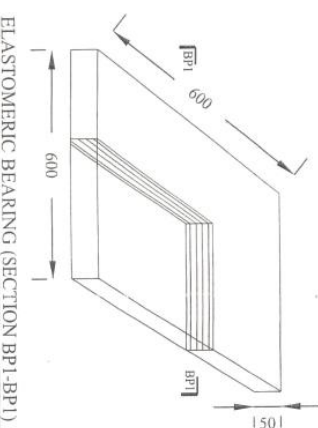

ELASTOMERIC BEARING (SECTION BP1-BP1)

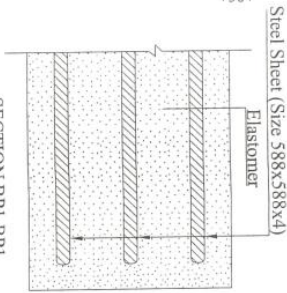

SECTION BP1-BP1

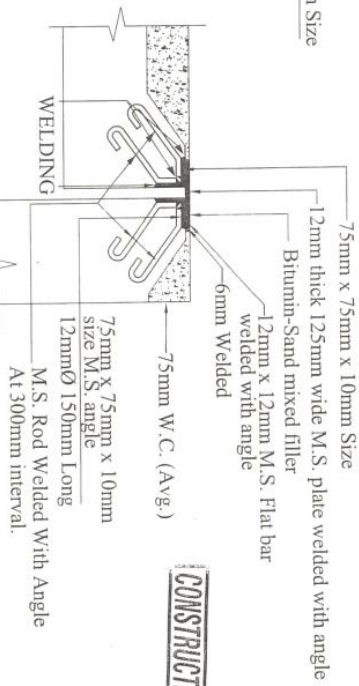

CONSTRUCTION DRAWINGS

REV	DATE	REVISIONS	DRAWN	DESIGNED	CHECKED	APPROVED	SCALE
01			NABI AMIN	M. SIDDIQ	SHAHZAD		1 : 100
02							
03							

Cross Section Of Approach Road

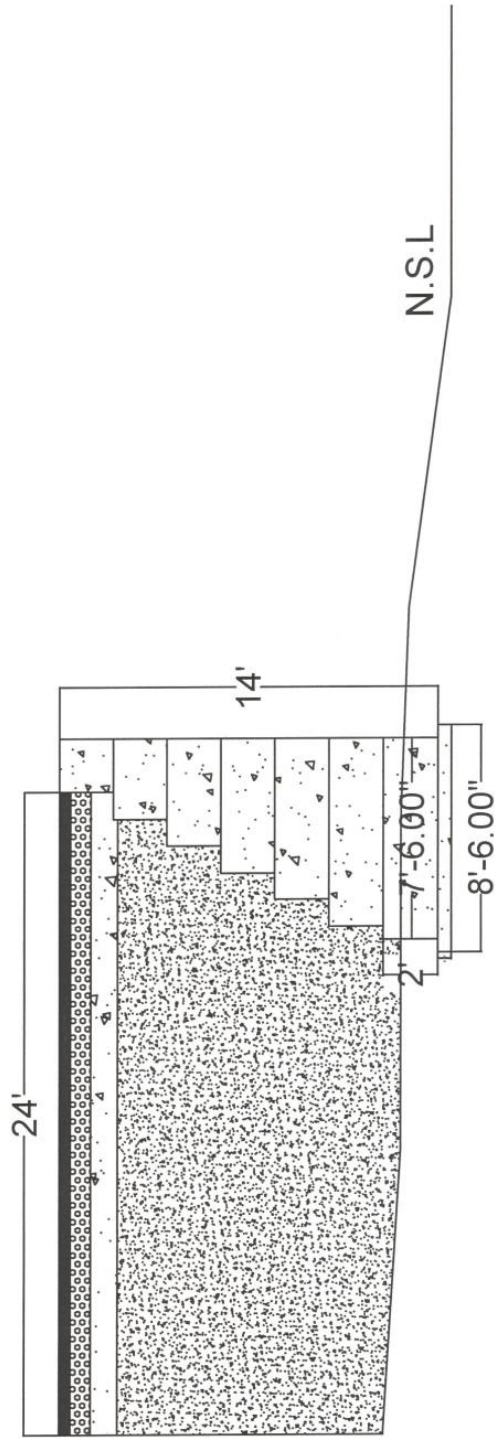

42

2" Asphalt Wearing Course and 3" Asphalt Base Course
 4" water Bound
 11" Sub Base Course

Embankment Of Embankment
 10.5' Avg Height

Handwritten signature and date: S/S 5/12

Cross Section of RRM Retaining Wall



43

D.B.L.	1159.130	1159.130							
Offset	426.131	26.63							
N.S.L.	1165.130	1167.832	1164.267	1162.148	1160.387	1158.000	1164.267	1162.663	1180.130
Offset	456.000	32.1000	1164.284	1162.148	1160.387	1158.000	1164.267	1162.663	0.000

Client:  IRRIGATION DEPT K.P.K CHARSADDA IRRIGATION DIVISION CHARSADDA	Title: 210455-Construction of Flood Protection works, Irrigation Channels and Ponds and Installation of Solar Irrigation Tube Wells in Khyber Pakhtunkhwa, ADP No.2267, during 2021-22.	Sub Title: Construction / Up-Gradation of Tatono Bridge (Dot-17) on Main Lower Swat Canal District Charsadda
--	---	--

Flood Protection work in Landi Khwar

Stone in G.I wire Crates

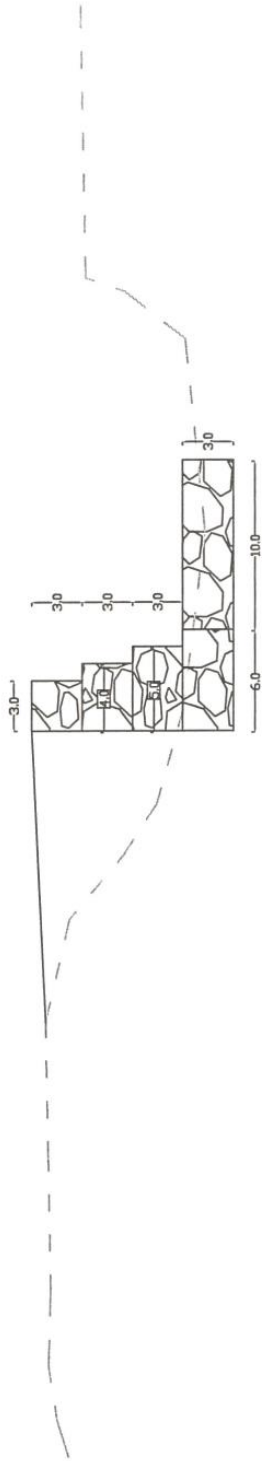

44

N.S.L.	0.000	980.309	2.077	980.966	5.357	981.485	9.948	981.344	17.943	981.504	25.934	981.664	32.062	980.235	35.881	977.008	38.903	975.047	44.486	973.488	55.024	972.183	66.498	973.344	69.286	976.964	70.075	979.284	86.003	979.598
--------	-------	---------	-------	---------	-------	---------	-------	---------	--------	---------	--------	---------	--------	---------	--------	---------	--------	---------	--------	---------	--------	---------	--------	---------	--------	---------	--------	---------	--------	---------

Title:

Client:

IRRIGATION DEPARTMENT KHYBER PAKHTUNKHWA
CHARSADDA IRRIGATION DIVISION CHARSADDA



Cut_Area (Sq Feet) 2356.0

RD 0+800 U/S

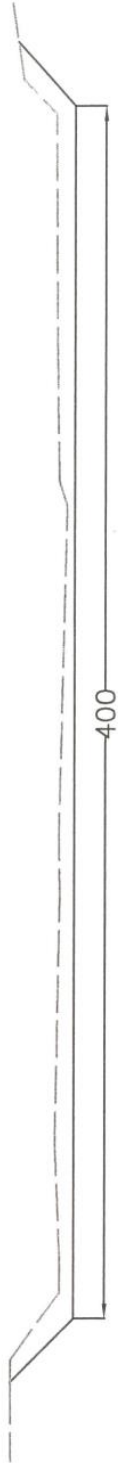

D.B.L.	160.250								
Offset	433.576								33.576
N.S.L.	180.992	164.849	164.849	164.849	166.550	165.079	165.470	162.840	166.558
Offset	180.992	180.992	180.992	180.992	180.992	180.992	180.992	180.992	180.992

 <p>IRRIGATION DEPT K.P.K CHARSADDA IRRIGATION DIVISION CHARSADDA</p>	<p>Title: 210455-Construction of Flood Protection works, Irrigation Channels and Ponds and Installation of Solar Irrigation Tube Wells in Khyber Pakhtunkhwa, ADP No.2267, during 2021-22.</p>	<p>Sub Title: Construction / Up-Gradation of Tatono Bridge (Dot-17) on Main Lower Swat Canal District Charsadda</p>
	<p>481.000 180.992</p> <p>459.000 180.992</p> <p>447.000 180.992</p> <p>425.000 164.849</p> <p>415.000 164.849</p> <p>374.999 166.550</p> <p>292.000 165.079</p> <p>274.000 165.470</p> <p>165.000 162.840</p> <p>157.000 165.474</p> <p>113.000 166.112</p> <p>36.000 166.558</p> <p>25.000 177.291</p> <p>0.000 181.210</p>	

Cut_Area (Sq Feet) 2071.0

RD 0+00



47

D.B.L.		1159.130	
Offset	426.131		26.63
N.S.L.	1165.130		1180.130
Offset	456.000	1183.446	0.000
			32.1.000
			1167.832
			94.000
			1199.984
			102.000
			1160.387
			113.000
			1162.663
			138.000
			1180.587
			1158.000
			1169.000
			1162.148
			181.000
			1164.267
			226.000
			1164.284
			281.000
			1181.975
			284.000
			1160.387
			295.000
			1161.975
			315.000
			1164.040
			349.000
			1160.387
			352.000
			1162.302
			360.000
			1160.511
			365.481
			1168.250
			415.481
			1165.130
			456.000
			1183.446
			426.131
			1159.130

Client:

 IRRIGATION DEPT
 K.P.K. CHARSADDA IRRIGATION
 DIVISION CHARSADDA

Title:
 210455-Construction of Flood Protection works, Irrigation
 Channels and Ponds and Installation of Solar Irrigation Tube
 Wells in Khyber Pakhtunkhwa, ADP No.2267, during 2021-22.

Sub Title:
 Construction / Up-Gradation of Tatono Bridge (Dot-17) on Main Lower Swat
 Canal District Charsadda

